

CE

**INSTALLATION and OPERATING  
INSTRUCTIONS**

**Air-to-Water Heat Pump  
for Outdoor installation**

**LA 6MR**

**LA 12TR**

**LA 8MR**

**LA 16TR**

**LA 10MR**

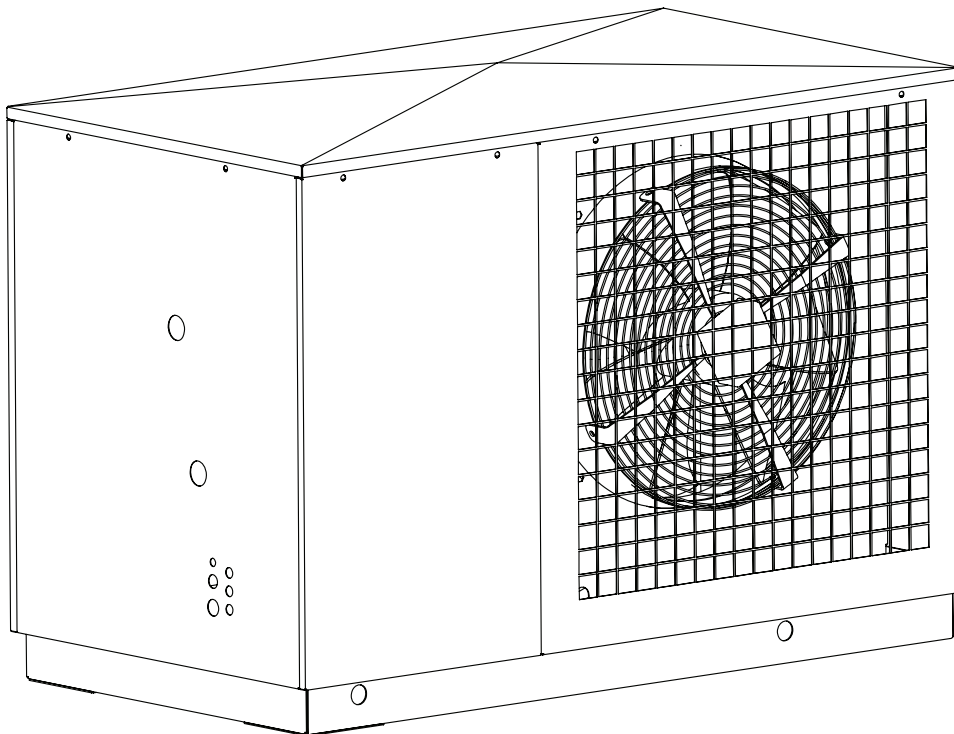

# CONTENTS

<b>1</b>	<b>READ IMMEDIATELY</b>	<b>3</b>
1.1	Important Information	
1.2	Legal Provisions and Guidelines	
1.3	Energy-Efficient Use of the Heat Pump	
<b>2</b>	<b>PURPOSE OF HEAT PUMP</b>	<b>4</b>
2.1	Field of Application	
2.2	Principle of Operation	
<b>3</b>	<b>SCOPE OF DELIVERY</b>	<b>4</b>
3.1	Baseline Unit	
3.2	Control Box	
<b>4</b>	<b>TRANSPORT</b>	<b>5</b>
<b>5</b>	<b>INSTALLATION</b>	<b>5</b>
5.1	General	
5.2	Condensate Line	
<b>6</b>	<b>MOUNTING</b>	<b>6</b>
6.1	General	
6.2	Heating-Side Connection	
6.3	Electrical Connection	
<b>7</b>	<b>COMMISSIONING</b>	<b>7</b>
7.1	General	
7.2	Preparatory Steps	
7.3	Procedure	
<b>8</b>	<b>FUNCTIONAL DESCRIPTION</b>	<b>8/9</b>
8.1	Heat Pump Remote Control Unit	
8.2	Control Board	
8.3	Heating Function	
8.4	Cooling Function	
8.5	Domestic Hot Water Function	
<b>9</b>	<b>CLEANING / CARE</b>	<b>9/10</b>
9.1	Care	
9.2	Cleaning of Heating Side	
9.3	Cleaning of Air Side	
<b>10</b>	<b>MALFUNCTIONS / TROUBLE-SHOOTING</b>	<b>10</b>
<b>11</b>	<b>DECOMMISSIONING</b>	<b>10</b>
11.1	End-of-Life Decommissioning / Disposal	
<b>12</b>	<b>APPENDIX</b>	<b>FF</b>

# 1 READ IMMEDIATELY

## 1.1 Important Information

**CAUTION!** Do not open the unit unless all electrical circuits have been disconnected from the power supply.

**CAUTION!** During transport, the heat pump must not be tilted more than 45° (in either direction).

**CAUTION!** Heat pump and transport pallet are only connected by the packaging film.

**CAUTION!** The air intake and discharge openings must neither be constricted nor obstructed.

**CAUTION!** Clockwise phase sequence (in the case of multiphase units) must be observed: Damage to the compressor may be incurred if it is operated in the wrong sense of rotation.

**CAUTION!** Do not use any cleaning agents containing sand, soda, acid or chloride as these may damage the surface.

**CAUTION!** To prevent consequential damage it is imperative that the water circuits be neutralized after cleaning using appropriate agents.

**CAUTION!** The unit is not suitable for operation with a frequency converter.

**CAUTION!** Work on the refrigeration circuit may be performed by qualified persons only.

## 1.2 Legal Provisions and Guidelines

This heat pump was designed and built in compliance with all relevant EU directives, DIN and VDE regulations (see CE Declaration of Conformity).

The electrical connection of the heat pump must be performed according to and conforming with all relevant VDE, EN and IEC standards. Beyond that, all technical connection requirements of the local electrical utility company have to be adhered to.

On connecting the heating system, all relevant regulations have to be heeded.

## 1.3 Energy-Efficient Use of the Heat Pump

By purchasing this heat pump you contribute to the protection of the environment. A prerequisite for energy-efficient operation is the proper design of the heat source system and the heat utilization system.

One of the most important factors of heat pump efficiency is keeping the temperature difference between the heating water and the heat source as small as possible. It is therefore strongly recommended that the design of both the heat source system and the heat distribution system be carried out with great care. **A 1 Kelvin (1°C) higher temperature difference corresponds to an increase in power consumption of approx. 2.5%.** When designing the heating system care must be taken that special applications such as domestic water heating are taken into consideration and dimensioned for low temperature operation. Heat pumps are optimally suited for **underfloor heating (surface/radiant heating) applications** due to the low supply temperatures (30 °C to 40 °C).

During operation it is essential that the heat exchangers are not contaminated as this would increase the temperature difference resulting in a lower coefficient of performance.

## PURPOSE OF HEAT PUMP SCOPE OF DELIVERY

# 2 PURPOSE OF HEAT PUMP

## 2.1 Field of Application

The air-to-water heat pump is intended for use in existing or newly built heating systems.

The heat pump is designed for the cooling or heating of water for heating purposes and the supply of domestic hot water!

The heat pump is suitable for mono-energetic and bivalent operation.

During heating mode, a heating water return temperature of more than 18 °C must be maintained in order to assure proper defrosting of the evaporator.

The heat pump is generally not designed for satisfying any increased heat demand during the drying phase of new buildings. The additional heat demand must therefore be met by special appliances to be supplied on site. For the structural drying of new buildings during autumn and winter, it is recommended that an additional electric heating element (available as an accessory) be installed.

**CAUTION!**

The unit is not suited for operation with a frequency converter.

## 2.2 Principle of Operation

Ambient air is drawn in by the fan and passed over a finned heat exchanger, which extracts heat from the air in the heating mode or gives off heat to the air in the cooling mode. This energy difference is transferred to the working fluid (refrigerant) in the heat exchanger.

With the aid of an electrically driven compressor, the absorbed heat is "pumped" to a higher temperature level through pressure increase and - depending on the particular application (cooling or heating) - is given off to the heating water or the waste air via the heat exchanger.

During heating mode, electrical energy is used to raise the heat of the environment to a higher temperature level. Due to the fact that the energy extracted from the air is transferred to the heating water, this type of appliance is referred to as air-to-water heat pump.

The air-to-water heat pump consists of the following main components: evaporator, fan and expansion valve as well as the low-noise compressor, a condenser and the electric control unit.

In the case of low ambient temperatures in the heating mode, moisture contained in the air may accumulate on the evaporator in the form of frost thus impairing the heat transfer. The evaporator is automatically defrosted by the heat pump, if required. Vapour pluming may occur at the air outlet depending on the weather conditions.

# 3 SCOPE OF DELIVERY

## 3.1 Baseline Unit

The heat pump is delivered as a compact unit containing the components listed below.

The refrigerant used is R407C.

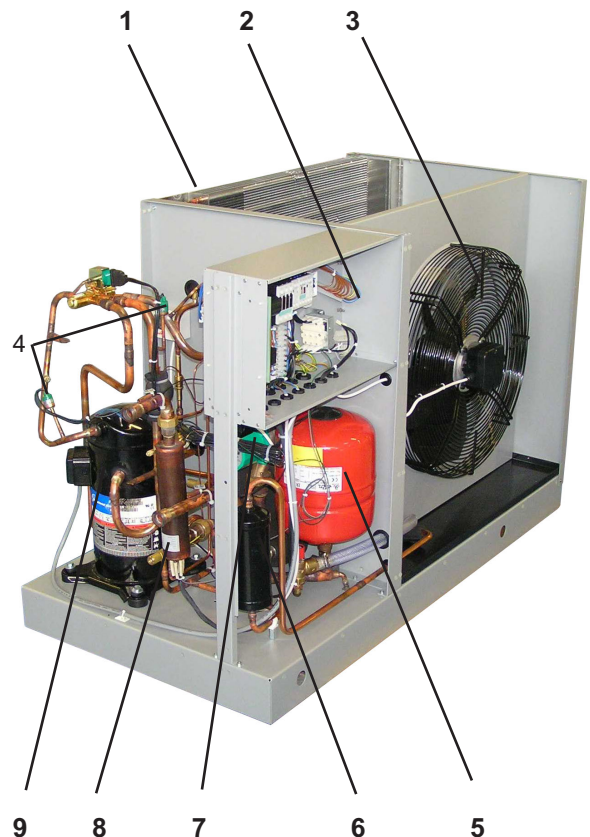

- |                     |                              |
|---------------------|------------------------------|
| 1) Evaporator       | 6) Receiver/<br>filter drier |
| 2) Control box      | 7) Circulat. pump            |
| 3) Fan              | 8) Electric heater           |
| 4) Pressostats      | 9) Compressor                |
| 5) Expansion vessel |                              |

## 3.2 Control Box

The control box is integrated in the heat pump. It is accessible after removal of the cover panel (the fastening screw holes of the cover panels are capped).

The control box houses the mains terminals, the power contactors, the soft start unit as well as the terminals for the remote control.

The control of the heat pump is effected via the remote control included in the scope of delivery (see also section 8.).

## 4 TRANSPORT

**CAUTION!** During transport, the heat pump must not be tilted more than 45° (in either direction).

The unit should be transported to the final installation site on a wooden pallet. The heat pump can be transported either by means of a lift truck or using 3/4" pipes to be passed through the openings provided in the base plate or in the frame.

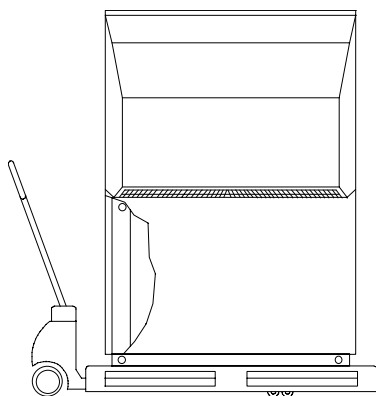

**CAUTION!** The heat pump and transport pallet are only connected by the packaging film.

When using 3/4" carrying pipes, be sure to secure them against shifting so as to avoid injuries (to your hands) during transport!

When slipping the carrying pipes through the frame, care must be taken that no components (in particular the plastic condensate pan or the drain pipe socket) are damaged.

## 5 INSTALLATION

### 5.1 General

The unit should always be installed on a permanently level, smooth and horizontal floor. The base frame (with its contact surfaces) should make close contact with the floor in order to prevent any structure-borne noise from being transmitted. If this is not possible, additional sound-absorbing measures might become necessary. It must be possible to carry out servicing activities without any problems. This is assured if a clearance of 1.2m is maintained all around the unit.

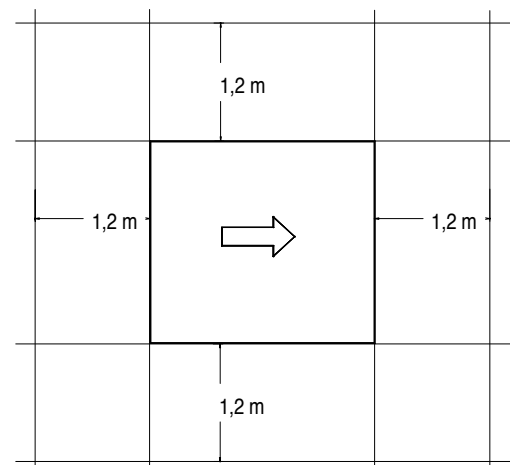

**CAUTION!** The air intake and discharge openings must not be restricted nor obstructed.

### 5.2 Condensate Line

The condensation water that may collect during operation must be drained in a place protected from frost. The heat pump must be positioned horizontally so that proper discharge can be ensured. The condensation water pipe must have a minimum diameter of 50 mm and should be discharged to the sewer drain in a frost-proof location.

The condensate pipe has to be placed centered underneath the drain pipe fitting of the condensate pan (see also dimensioned drawing in the Appendix). Alternative condensate discharge options have to be agreed with the manufacturer.

**Do not discharge the condensate directly into septic pits or cesspools as the evaporator is likely to be destroyed by the aggressive vapours generated there.**

# 6 MOUNTING

## 6.1 General

The following connections need to be established on the heat pump:

- supply/return lines of the heating system
- condensate drain
- control lead to the remote control
- power supply

## 6.2 Heating-Side Connection

The connections on the heating side of the heat pump are provided with 1" external thread (flat sealing). When making the connections to the heat pump, use a wrench to counterhold at the transitions.

Before completing the heat pump connections on the heating water side, the heating installation must be flushed in order to remove any impurities that may be present, as well as any residues of sealing material, and the like. Any accumulation of deposits in the condenser may result in a total failure of the heat pump. On systems equipped with heating water flow shut-off devices such as radiator or thermostat valves, an overflow valve, to be provided by the customer, needs to be installed at the outlet of the heat pump in a heating system bypass. This assures a minimum heating water flow through the heat pump and thus prevents any malfunctions from occurring.

Once the installation on the heating side has been completed, the heating system must be filled, de-aerated and pressure-tested..

### Heating water minimum flow rate

The heating water minimum flow rate through the heat pump must be assured in all operating states of the heating system. This can be accomplished, for example, by installing a differential pressure-free manifold or an overflow valve. The procedure for setting an overflow valve is described in the Chapter Commissioning.

### Frost Protection

On heat pumps installed in a location prone to frost, a manual drain valve (see "Hydraulic Block Diagrams" in the Appendix) should be provided. Properly installed appliances feature an internal frost protection feature. If the heat pump is taken out of service or in the event of a power failure, the system must be drained. In heat pump installations where a power failure cannot be readily detected (e.g. holiday houses), the heating circuit must contain a suitable antifreeze product.

## 6.3 Electrical Connection

The power connection of the heat pump is effected via a standard 3-core (for 1-phase units) or a 5-core (for 3-phase units) cable.

In the case of the 1-phase units, an additional 3-core cable must be installed for the electric back-up heater.

The cable(s) has (have) to be supplied by the client; the cross-sectional area is to be selected in accordance with the power consumption of the heat pump (see Equipment Data in the appendix) as well as all relevant VDE (EN) and VNB regulations.

The power supply of the heat pump must be equipped with an all-pole disconnecting device with a contact gap of at least 3 mm (e.g. utility company shut-off contactor, power contactor) as well as a 3-pole circuit breaker, with simultaneous tripping of all external conductors (tripping current as stated in the Equipment Data).

- optionally, an additional three-core cable is required for the domestic hot water supply.

When connecting multiphase units the clockwise phase sequence of the motor electrical supply must be assured.

Phase sequence: L1, L2, L3.

## CAUTION!

**Clockwise phase sequence (in the case of multiphase units) must be ensured: Operating the compressor in the wrong sense of rotation, may result in damage to the compressor. An incorrect phase sequence causes the fan to operate in the wrong sense of rotation leading to a significant reduction in performance.**

The control voltage for the remote control is provided by the power supply of the unit.

The connecting lead (control lead) from the remote control to the heat pump (not included in the scope of delivery) must be suitable for 230 V mains power supply. The lead must have (at least) 6 cores and the cross-section of the single cores must be at least 0.5 mm<sup>2</sup>.

The power supply of the heat pump must be as specified in the Technical Data of the appliance, i.e. 230 V AC 50 Hz or 3-L/N/PE 400 V.

The connection inside the heat pump is to be effected using the terminal strips in the control box. For detailed information refer to the Wiring Diagrams in the Appendix.

# 7 COMMISSIONING

## 7.1 General

To ensure proper commissioning it should be carried out by an after-sales service authorized by the manufacturer. Only then can an extended warranty period of 3 years in total be granted (cf. Warranty service).

## 7.2 Preparatory Steps

Prior to commissioning, the following items need to be checked:

- All connections of the heat pump must have been made as described in Chapter 6.
- In the heating circuit all valves that could impair the proper heating water flow must be open.
- The air intake/discharge path must be unobstructed.
- The sense of rotation of the fan must correspond to the direction of the arrow.
- An operating mode must have been set on the remote control.
- Proper condensate drainage must be ensured.

## 7.3 Procedure

The start-up of the heat pump is effected via the remote control.

Where an overflow valve is fitted to assure the minimum heating water flow rate, the valve must be set in accordance with the specific requirements of the heating installation. An incorrect setting may result in various error symptoms and an increased electric power consumption. To correctly set the overflow valve, the following procedure is recommended for the "heating mode":

Close all of the heating circuits that may also be closed during operation (depending on the type of heat pump usage) so that the least favourable operating state - with respect to the water flow rate - is achieved. Typically these are the heating circuits of the rooms on the building's south and west sides. At least one heating circuit must remain open (e.g. bathroom).

The overflow valve is to be opened to such an extent that based on the current heat source temperature the maximum temperature spread between heating supply and return flow temperature is obtained, as indicated in the table that follows. The temperature spread should be measured as closely to the heat pump as possible. In mono-energetic systems, the electric heating element is to be deactivated.

Heat source temperature from	Heat source temperature to	max. difference between heating water supply and return temperature
-20 °C	-15 °C	4 K
-14 °C	-10 °C	5 K
-9 °C	-5 °C	6 K
-4 °C	0 °C	7 K
1 °C	5 °C	8 K
6 °C	10 °C	9 K
11 °C	15 °C	10 K
16 °C	20 °C	11 K
21 °C	25 °C	12 K
26 °C	30 °C	13 K
31 °C	35 °C	14 K

The following procedure must be observed so that the commissioning activities can be carried out without any problems:

- a) Close all heating circuits.
- b) Open the overflow valve all the way.
- c) Wait until the buffer tank has reached a temperature of approx. 25 °C.
- d) Subsequently, slowly reopen the valves of the heating circuits, one after the other, in such a way that the heating water flow rate is continually increased by slightly opening the related heating circuit. When so doing, the heating water temperature in the buffer tank must not fall below 20 °C so that the heat pump can be defrosted at any time.
- e) Once all heating circuit are fully open and a heating water temperature of approx. 20 °C is maintained in the buffer tank, the minimum flow rate must be set on the overflow valve and the heating circulating pump.

# 8 FUNCTIONAL DESCRIPTION

## 8.1 Heat Pump Remote Control Unit

The heat pump can be switched on and off by means of the remote control positioned inside the building. Switching off in this case means switching to a "standby" function, i.e. as long as the heat pump is supplied with mains power, the frost protection function of the heat pump remains active. If the water temperature is too low, first the heating circulating pump, and if this is not enough, also the compressor must be put in operation. The remote control allows you to set the heating or cooling operating mode (the switchover delay from the heating to the cooling mode, or vice-versa, is 10 min.) as well as the temperature level of the heating water.

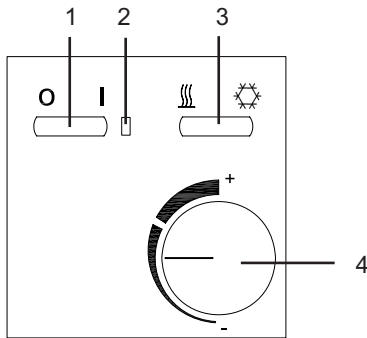

- 1) Switch On/Standby
- 2) LED (green) is illuminated regardless of the switch position (indicates operational readiness of heat pump)
- 3) Switch "Heating" (left side depressed)  
Switch "Cooling" (right side depressed)
- 4) Dial for selecting heating water setpoint temperature

## 8.2 Control Board

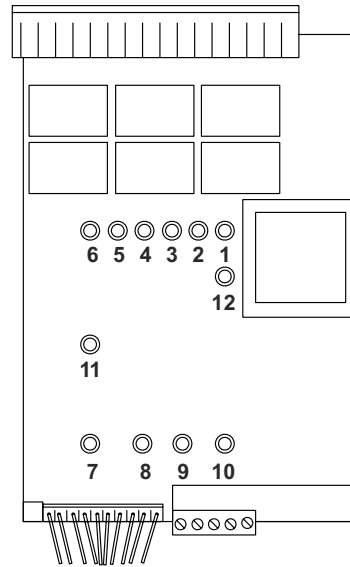

- 1) on = compressor is operating
- 2) on = fan is operating
- 3) off = reversing valve set to "Heating"  
on = reversing valve set to "Cooling" or "Defrost"
- 4) on = heating circulating pump is operating
- 5) off = output backup heater off
- 6) on = call for frost protection, HP is heating  
off = call for frost protection off
- 7) on = low pressure pressostat okay
- 8) off = defrost process in progress or "Heating mode"  
on = defrost process is terminated or "Cooling mode"
- 9) not used
- 10) not used
- 11) flashing during operation
- 12) flashing in the event of a malfunction

## 8.3 Heating Function

Set switch (1) to position On (I) to put heat pump into operation. The heating mode can be preselected by placing switch (3) to the Heating ( ))) position. The desired return temperature can be set using selector dial (4), the relevant call for heat is controlled by the potentiometer and lies within a range of min. 10 °C and max. 55 °C. If the preset temperature is reached, the heat pump switches off. Once the return temperature drops below the preset temperature by 4 Kelvin, the heat pump switches back on. In the event that the preset return temperature cannot be reached, the output for the back-up heater cuts in after approx. 1 hour. The heat pump cannot be restarted until a minimum time delay of 5 minutes has elapsed. At a supply temperature of approx. 60 °C or if the air temperature is too low, the heat pump switches off.



## 8.4 Cooling Function

Place switch (1) in position On (I) to put heat pump into operation. The cooling mode can be preselected by placing switch (2) to the Cooling (❄️) position. The desired return temperature can be set using selector dial (4), the relevant call for heat is controlled by the potentiometer and lies within a range of min. 12 °C and max. 25 °C. When the preset temperature is reached, the heat pump switches off. Once the return temperature exceeds the preset value by 4 Kelvin, the heat pump switches back on. The heat pump cannot be restarted until a minimum time delay of 5 minutes has elapsed. At a supply temperature of below 7 °C, the heat pump switches off.

**To prevent condensate from forming on the system in the case of surface cooling systems, it is recommended that dew point monitors be installed at critical places of the cold distribution system and connected in lieu of jumper A1. In the event that condensation should form, the cooling operation of the system will be interrupted.**

## 8.5 Domestic Hot Water Function

This heat pump can also be used for heating domestic water.

The call for domestic water heating (and the domestic water temperature) is controlled by terminal "X2-7" by means of a thermostat to be provided by the client. This thermostat connects phase (L) to terminal "X2-7" and controls a reversing valve which is part of the hot water switch group "N13".

A suitable thermostat is available as an accessory.

The call for domestic water heating may also occur if no call for space heating exists. On a call for heat, the control unit switches off the heating circulating pump and the setpoint is set to maximum.

The water temperature is now controlled by the external thermostat. After the domestic hot water preparation has been terminated, the system returns to the same function that was active before the call.

# 9 CLEANING / CARE

## 9.1 Care

To protect the paint finish, avoid placing objects against or on the unit. The external parts of the heat pump can be wiped with a damp cloth and commercially available cleaning agents.

**CAUTION!** Do not use any cleaning agents containing sand, soda, acid or chloride as these may damage the surface.

To prevent malfunctions due to dirt deposits in the plate heat exchanger of the heat pump, care must be taken that the heat exchanger cannot become contaminated in the heating installation. In the event that operating malfunctions due to contamination occur nevertheless, the system should be cleaned as described below. (Caution: The fins of the finned heat exchanger have sharp edges -> risk of cutting injuries!)

## 9.2 Cleaning of Heating Side

The ingress of oxygen into the heating water may result in the formation of oxidation products. An additional contamination of the heating water caused by residues of lubricating and sealing agents occurs in many cases.

Both of the above causes may lead to a reduction in the performance of the plate heat exchanger of the heat pumps. In such cases, the installer must clean the heat exchanger concerned. Based on information known to date we recommend cleaning with a 5% phosphoric acid solution or, in the case that cleaning needs to be performed more frequently, with a 5% formic acid solution. In both cases the cleaning fluid should be at room temperature. Thorough flushing is necessary to ensure that all cleaning agent residues are removed from the system. It is recommended that the heat exchanger be cleaned in the direction opposite to the normal flow direction. Owing to their acid content, flushing agents must be used with caution. To prevent acidic flushing agents from entering the heating installation when cleaning the condenser, we recommend that the flushing device be mounted directly to the supply and return line of the heat pump. The regulations of the trade associations must be adhered to. If in doubt, contact the manufacturers of the chemicals!

**CAUTION!** To prevent consequential damage it is imperative that the water circuit be neutralized after cleaning using appropriate agents.

## CLEANING / CARE MALFUNCTIONS / TROUBLESHOOTING DECOMMISSIONING

### Caution - Heating Contractors

Depending on the water quality and quantity, in particular in the case of mixed installations and plastic pipes, mineral deposits (rust sludge, lime) may form impairing the proper functioning of the heating installation. A cause of this is the water hardness as well as oxygen dissolved in the filling water as well as additional oxygen from the air which may penetrate via valves, fittings and plastic pipes (oxygen diffusion). As a preventive measure it is recommended that a physical water conditioner such as ELYSATOR be used.

### 9.3 Cleaning of Air Side

Finned heat exchangers, fan and condensate drain should be cleaned of debris (leaves, branches, etc.) prior to the start of the heating season. Contamination of this nature can be removed manually using compressed air or by washing off with clear water.

The appliance cover and the air intake grille may have to be removed for this purpose.

## CAUTION!

**Prior to opening the unit it must be ensured that all electrical circuits are disconnected from the power supply.**

When cleaning do not use any sharp or hard objects so as to prevent any damage to the evaporator and the condensate pan.

Extreme weather conditions (e.g. heavy snow) may in some cases result in ice build-up on the inlet and outlet grilles. To assure a minimum air flow rate, clear the inlet and discharge areas of snow and ice, if needed.

## 10 MALFUNCTIONS / TROUBLESHOOTING

This heat pump is a quality product and is designed for troublefree and maintenance-free operation. In the event that a malfunction occurs nevertheless, you will be able to correct the problem easily yourself in the majority of cases.

Heat pump does not run!  
Please check that:

- there is no problem with the power supply (blown fuse, power failure).
- the power switch on the remote control is switched on and the correct operating mode is selected, as well as that the correct setpoint temperature is set.

The preset temperature level cannot be reached!  
Please check whether

- the permissible operating conditions of the heat pump are complied with (air temperatures too high or too low).
- the air inlet or outlet areas are neither covered, obstructed nor severely contaminated.
- valves or stop-cocks in the water lines (heating lines) are closed.
- the water temperature in the buffer tank is sufficiently high.

If you cannot eliminate the malfunction yourself, please contact your customer service in charge (see Warranty Certificate).

## CAUTION!

**Work on the heat pump may be done only by an authorized and qualified customer service.**

## 11 DECOMMISSIONING

### 11.1 End-of-Life Decommissioning / Disposal

Before removing the heat pump, disconnect the appliance from the power supply and close all valves. Environment-relevant requirements regarding the recovery, recycling and disposal of service fuels and components in accordance with all relevant standards must be adhered to. In this context, particular attention must be paid to the proper disposal of refrigerants and refrigeration oils.

# 12 APPENDIX

<b>12.1</b>	<b>DIMENSIONED DRAWING</b>	<b>12</b>
<b>12.2</b>	<b>EQUIPMENT DATA</b>	<b>13</b>
<b>12.3</b>	<b>SCHEMATICS</b>	
12.3.1	Heating mode LA 6MR	14
12.3.2	Cooling mode LA 6MR	15
12.3.3	Heating mode LA 8MR	16
12.3.4	Cooling mode LA 8MR	17
12.3.5	Heating mode LA 10MR	18
12.3.6	Cooling mode LA 10MR	19
12.3.7	Heating mode LA 12TR	20
12.3.8	Cooling mode LA 12TR	21
12.3.9	Heating mode LA 16TR	22
12.3.10	Cooling mode LA 16TR	23
<b>12.4</b>	<b>WIRING DIAGRAMS</b>	
12.4.1	Control LA 6MR-LA 10MR	24
12.4.2	Load LA 6MR-LA 10MR	25
12.4.3	Terminal Diagram LA 6MR-LA 10MR	26
12.4.4	Legend LA 6MR-LA 10MR	27
12.4.5	Control LA 12TR-LA 16TR	28
12.4.6	Load LA 12TR-LA 16TR	29
12.4.7	Terminal Diagram LA 12TR-LA 16TR	30
12.4.8	Legend LA 12TR-LA 16TR	31
<b>12.5</b>	<b>HYDRAULIC BLOCK DIAGRAMS</b>	
12.5.1	Mono-energetic system	32
12.5.2	Mono-energetic system and domestic hot water function	33
<b>12.6</b>	<b>EC DECLARATION OF CONFORMITY</b>	<b>34</b>

Dimensioned Drawing

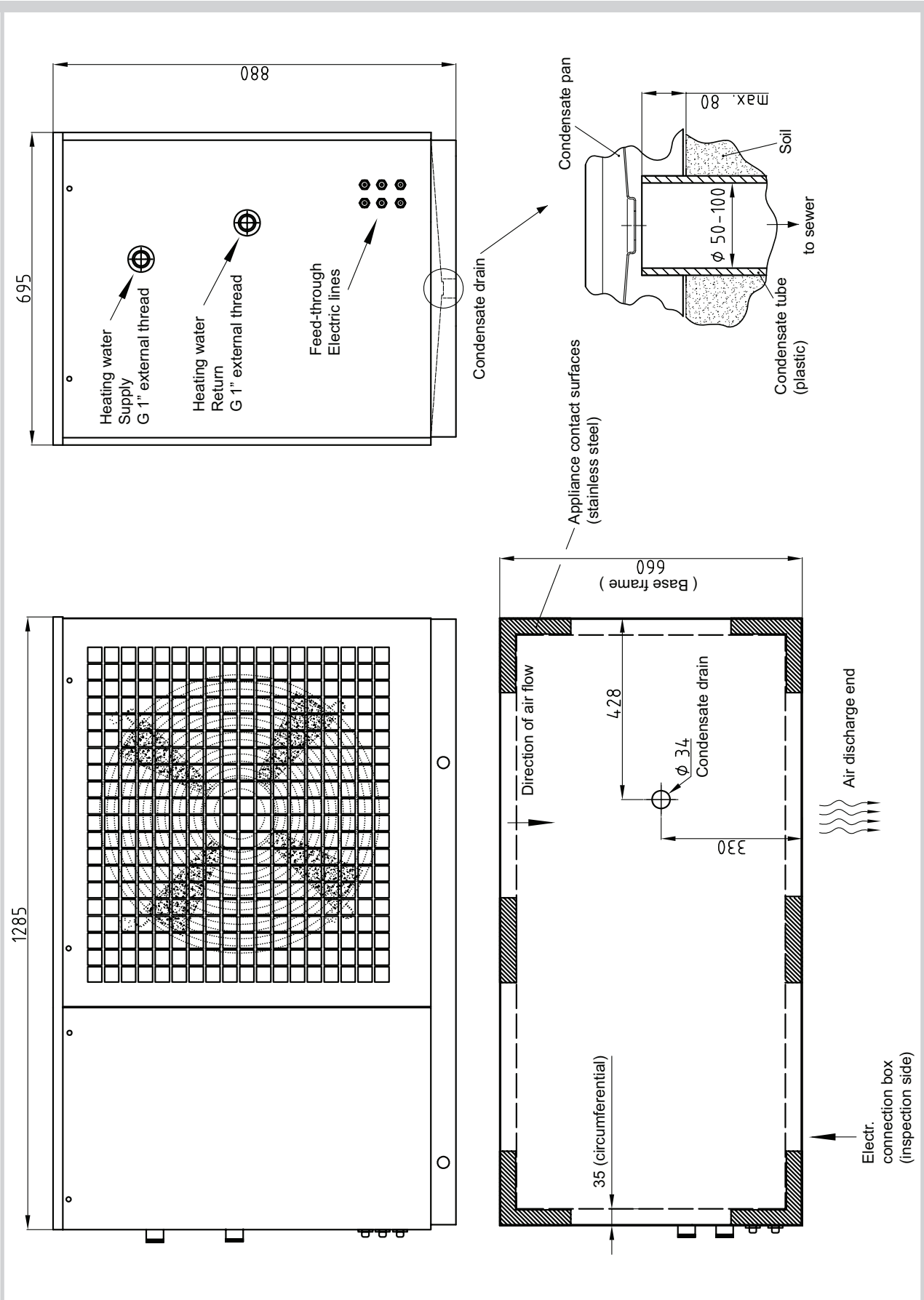

Equipment Data

EQUIPMENT DATA for air-to-water heat pumps for heating						
1	TYPE AND COMMERCIAL DESCRIPTION	LA06MRN	LA08MRN	LA10MRN	LA12TRN	LA16TRN
2	MODEL					
2.1	Type	reversible	reversible	reversible	reversible	reversible
2.2	Enclosure type acc. to EN 60 529 for compact unit and/or heating element	IP 24	IP 24	IP 24	IP 24	IP 24
2.3	Installation site	outdoors	outdoors	outdoors	outdoors	outdoors
3	PERFORMANCE DATA					
3.1	Operating temperature limits:					
	Heating water supply / return °C / °C	max.60/min.18	max.60/min.18	max.60/min.18	max.60/min.18	max.60/min.18
	Cooling, flow °C	+7 to +20	+7 to +20	+7 to +20	+7 to +20	+7 to +20
	Air (heating) °C	-20 to +35	-20 to +35	-20 to +35	-20 to +35	-20 to +35
	Air (cooling) °C	+15 to +45	+15 to +45	+15 to +45	+15 to +45	+15 to +40
3.2	Heating capacity / coeff. of perform. at A7 / W35 1) kW / ---	6.1 / 3.3	7.4 / 3.3	8.5 / 3.4	11.9 / 3.3	15.3 / 3.3
	at A7 / W45 1) kW / ---	6.1 / 2.7	7.3 / 2.7	8.4 / 2.8	11.6 / 2.7	14.9 / 2.8
3.3	Cooling capacity / coeff. of perform. at A35 / W18 kW / ---	7.9 / 3.2	9.4 / 3.3	11.1 / 3.3	15.8 / 3.3	18.5 / 3.3
	at A35 / W7 kW / ---	6.4 / 2.7	7.7 / 2.9	9.0 / 2.9	13.6 / 3.0	16.1 / 3.0
3.4	Sound power level dB(A)	70	71	71	72	72
3.5	Sound pressure level at 10 m distance (discharge side) dB(A)	45	46	46	47	47
3.6	Heating water flow rate m³/h	1.1	1.3	1.5	1.7	1.9
3.7	Free pressure, heating circulating pump (max. stage) Pa	34800	35600	33800	32700	58900
3.8	Refrigerant; total charge weight type / kg	R407C / 1.5	R407C / 2.3	R407C / 2.3	R407C / 3.4	R407C / 3.7
3.9	Rating electric heating element (back-up heater) max. kW	6	6	6	6	6
4	DIMENSIONS; CONNECTIONS AND WEIGHT					
4.1	Equipment dimensions H x W x L cm	86 x 127 x 67	86 x 127 x 67	86 x 127 x 67	86 x 127 x 67	86 x 127 x 67
4.2	Equipment connections for heating inch	G 1" external	G 1" external	G 1" external	G 1" external	G 1" external
4.3	Weight of transport unit(s) incl. packaging kg	159	165	170	185	196
5	ELECTRICAL CONNECTION					
5.1	Nominal voltage; fusing V / A	230 / 20	230 / 20	230 / 25	400 / 20	400 / 25
5.2	Fuse protection, electric heating element (only 230V units) A	30 4)	30 4)	30 4)	-	-
5.3	Nominal power consumption 1) A2 W35 kW	1.9	2.3	2.5	3.6	4.6
5.4	Starting current with soft starter A	26	32	38	26	27
5.5	Nominal current A2 W35 / cos φ A / ---	10.3	12.5	13.6	6.5	8.3
6	COMPLIES WITH EUROPEAN SAFETY REGULATIONS	3)	3)	3)	3)	3)
7	OTHER DESIGN CHARACTERISTICS					
7.1	Defrosting	automatic	automatic	automatic	automatic	automatic
	Defrost type	cycle reversal	cycle reversal	cycle reversal	cycle reversal	cycle reversal
	Defrost pan available	yes (heated)	yes (heated)	yes (heated)	yes (heated)	yes (heated)
7.2	Heating water inside unit protected against freezing	yes 2)	yes 2)	yes 2)	yes 2)	yes 2)
7.3	Performance settings	1	1	1	1	1
1)	These data characterize the size and performance of the system. For economic and energetic considerations, additional factors such as defrosting behaviour, bivalence point and control need to be taken into account. Abbreviations have the following meaning: e.g. A7 / W35: outside temperature 7 °C and heating water supply temperature 35 °C.					
2)	The heating circulating pump and the controller of the heat pump must be on standby at all times.					
3)	See EC Declaration of Conformity					
4)	For the electr. connection of the electric heating element, a separate load line with its own fuse protection is required.					
	Subject to change without notice		Issued: 02.03.2006			

12.3.1 Heating mode LA 6MR

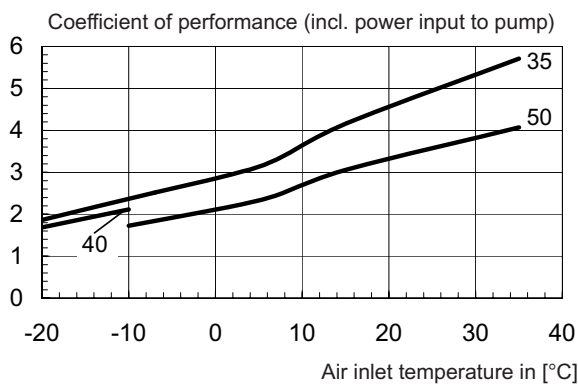
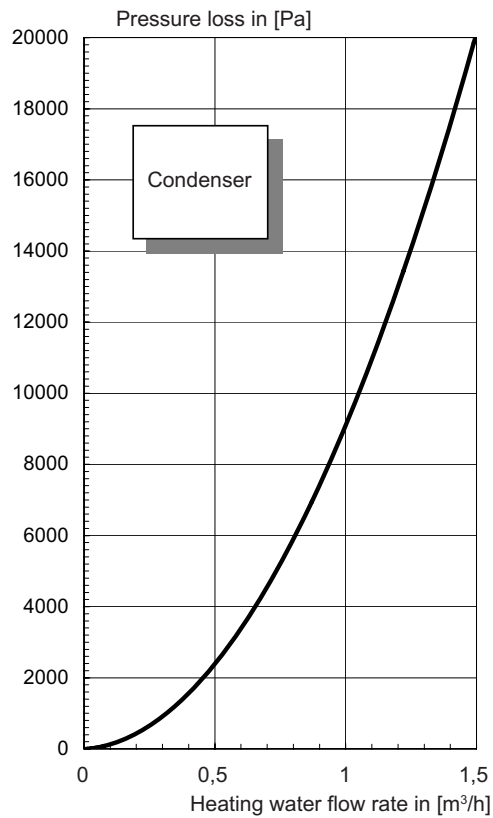
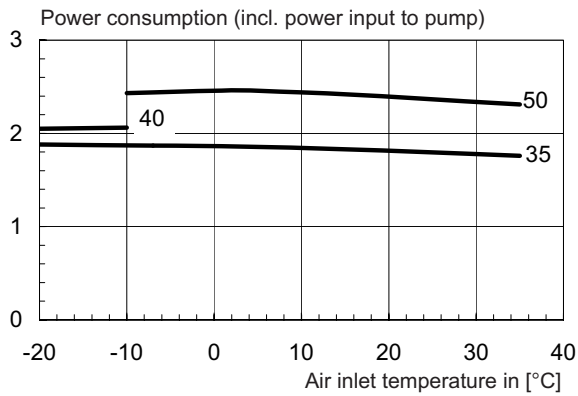
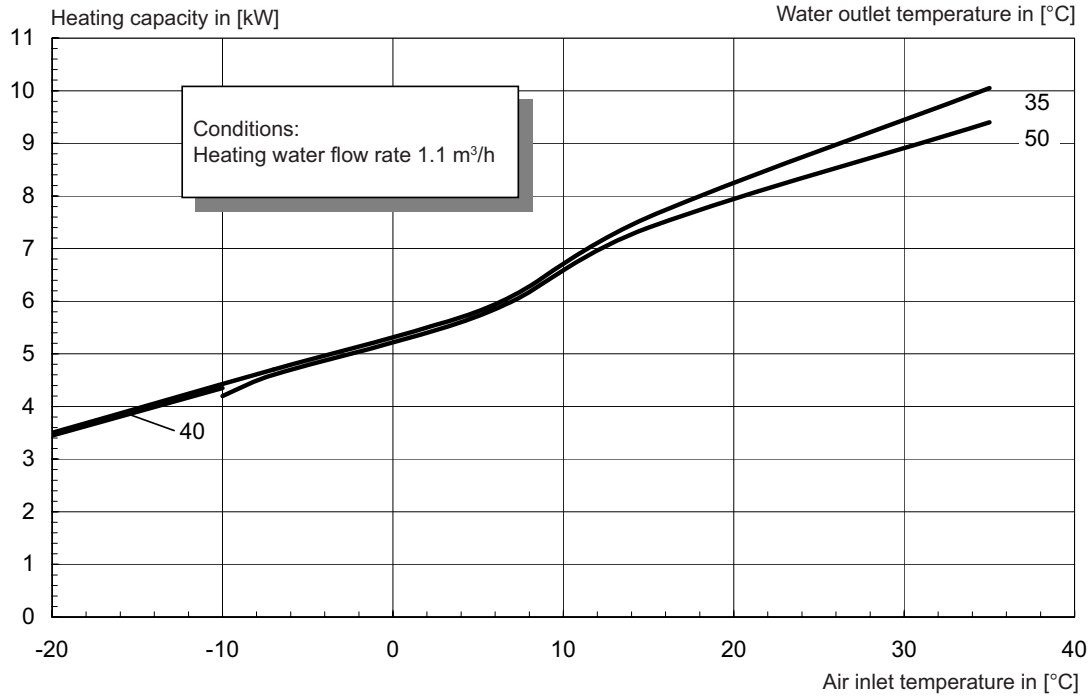

12.3.2 Cooling mode LA 6MR

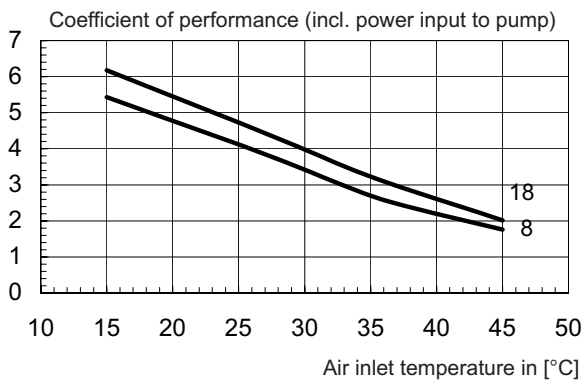
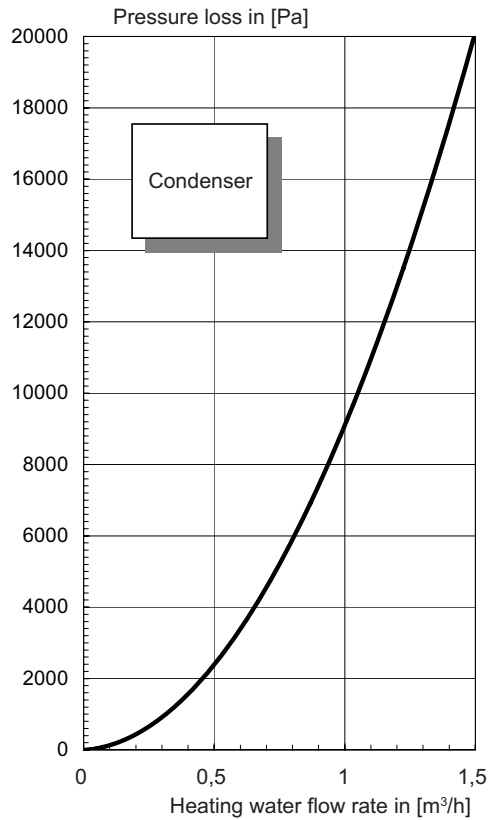
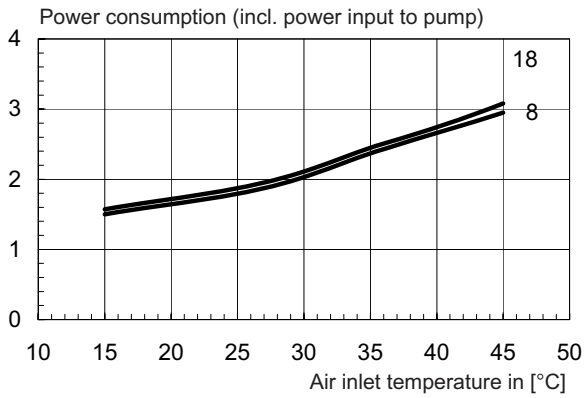
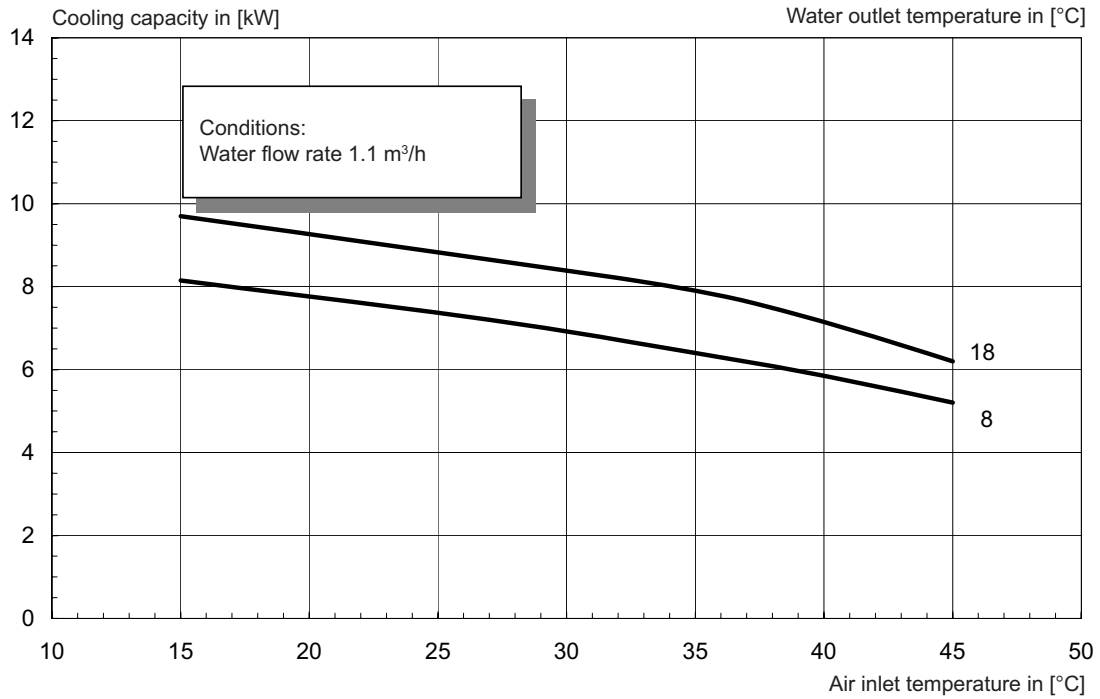

12.3.3 Heating mode LA 8MR

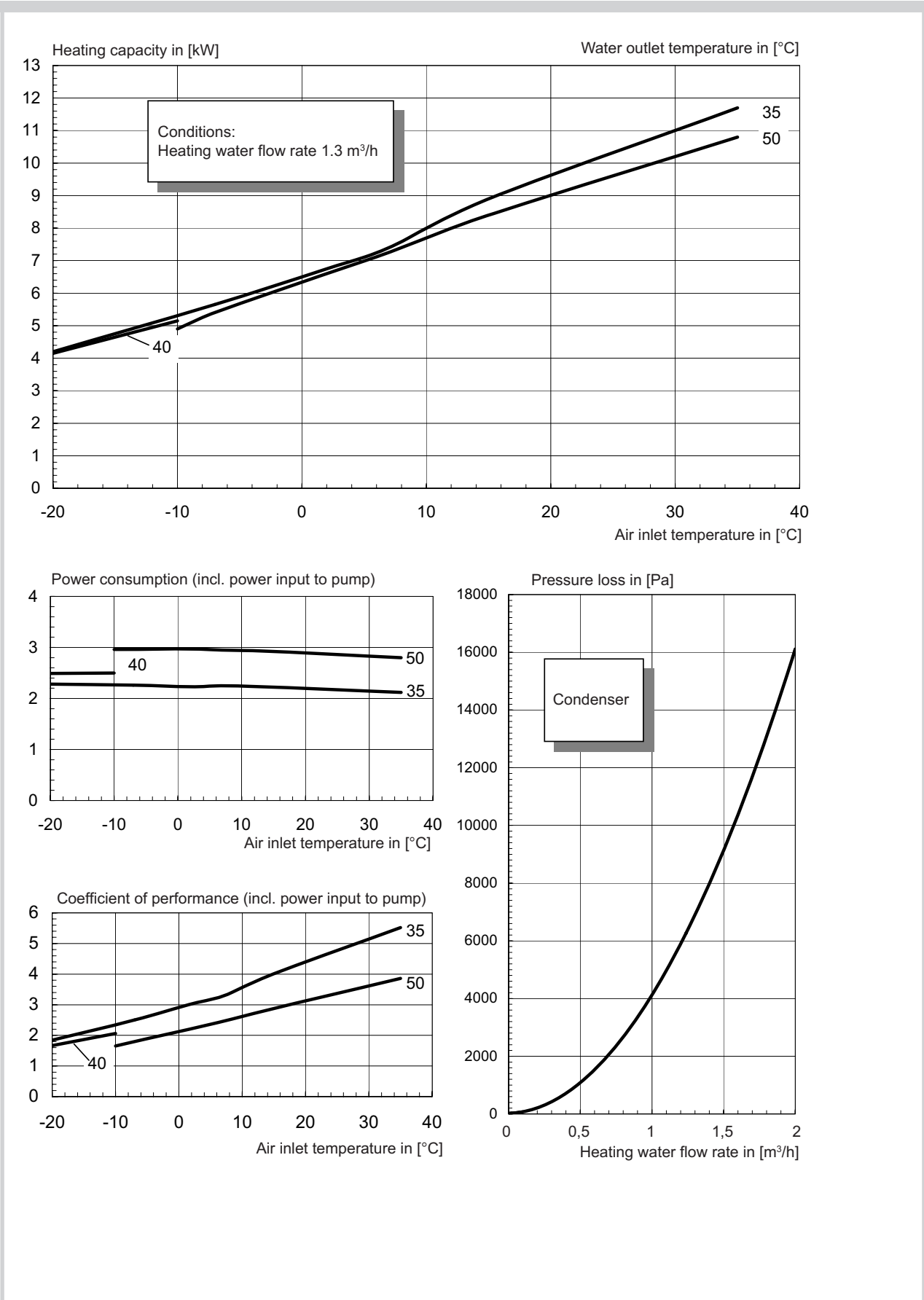



12.3.4 Cooling mode LA 8MR

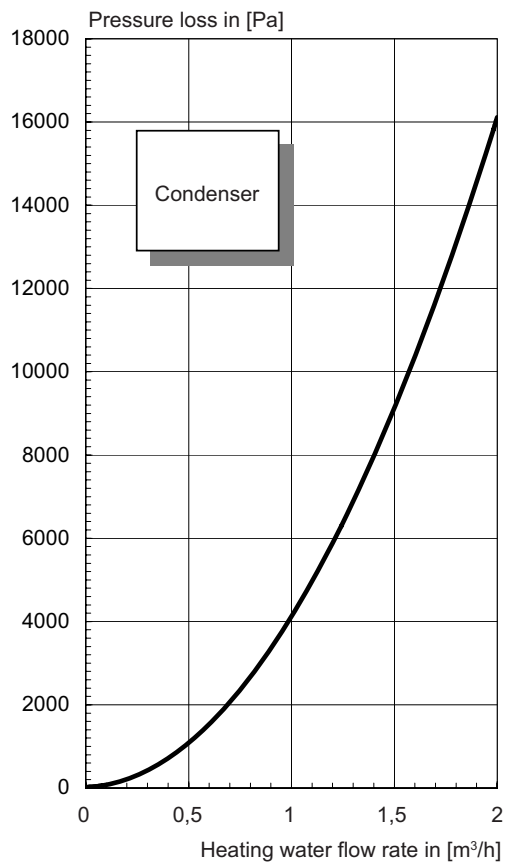
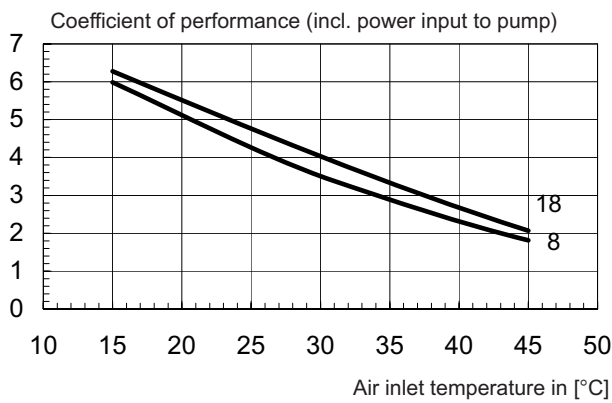
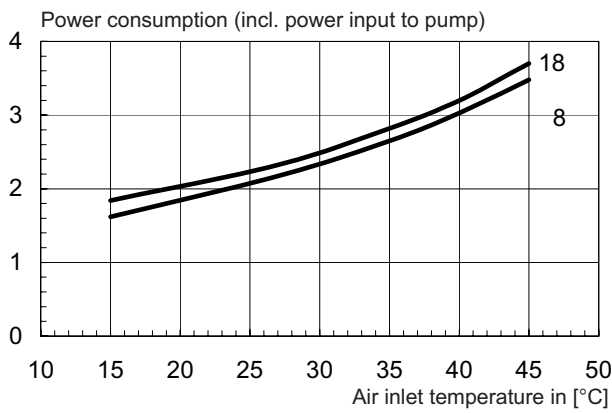
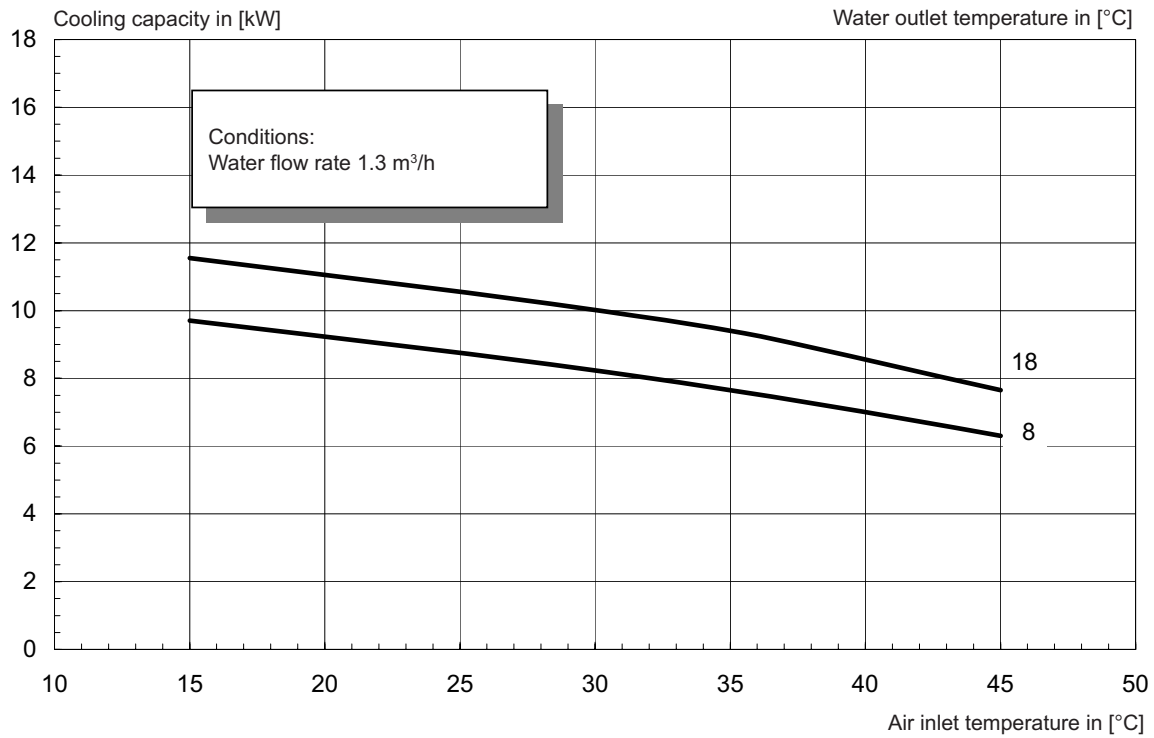

12.3.5 Heating mode LA 10MR

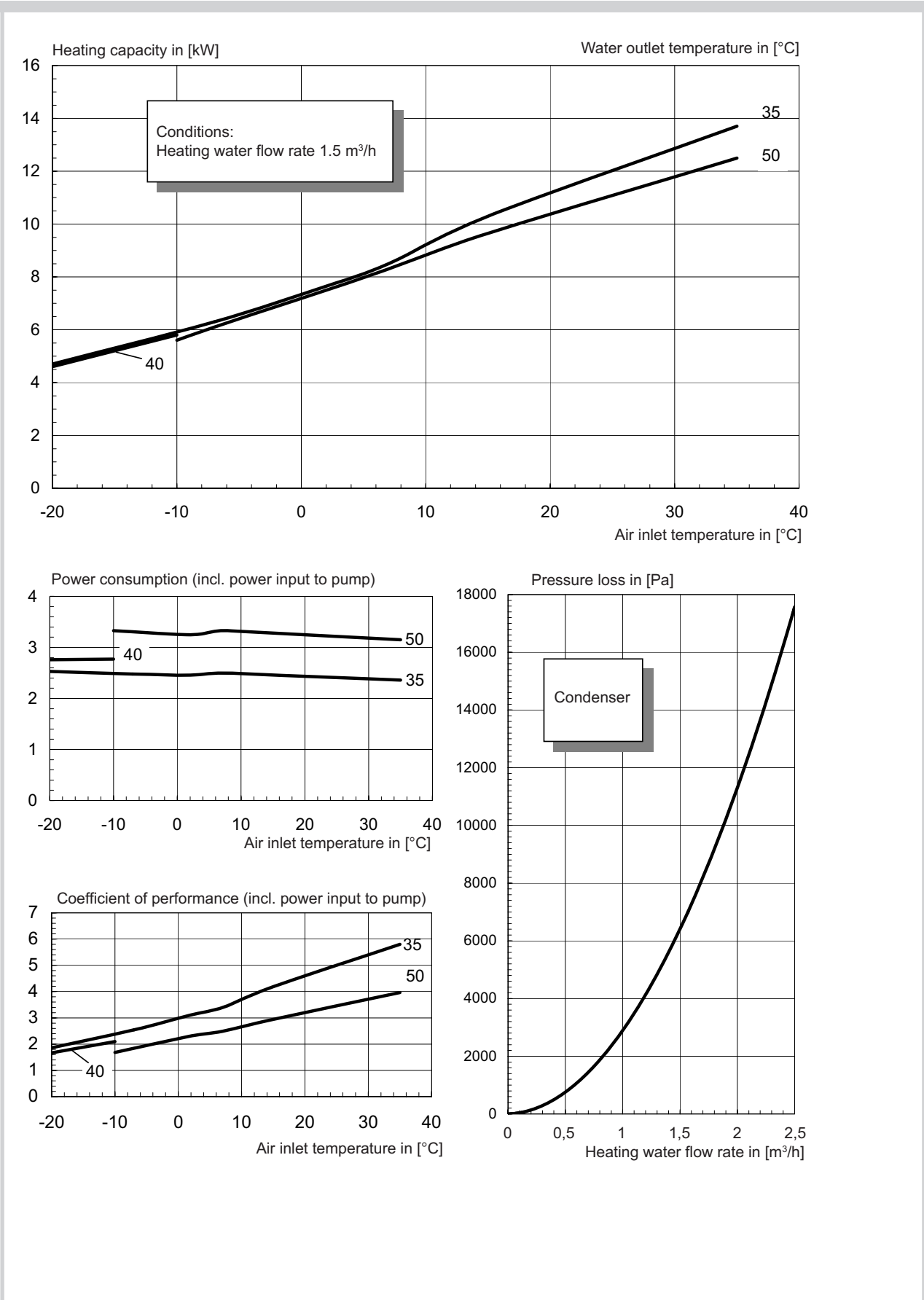

12.3.6 Cooling mode LA 10MR

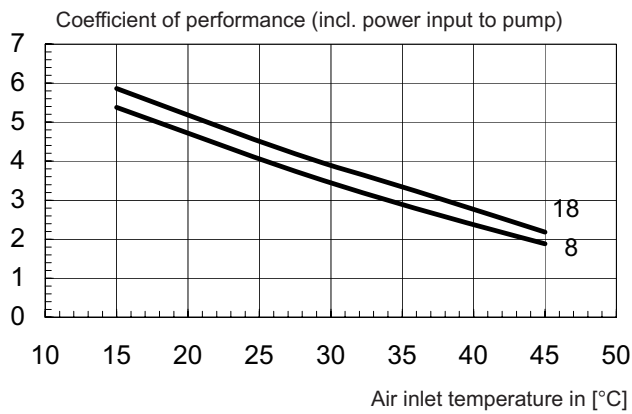
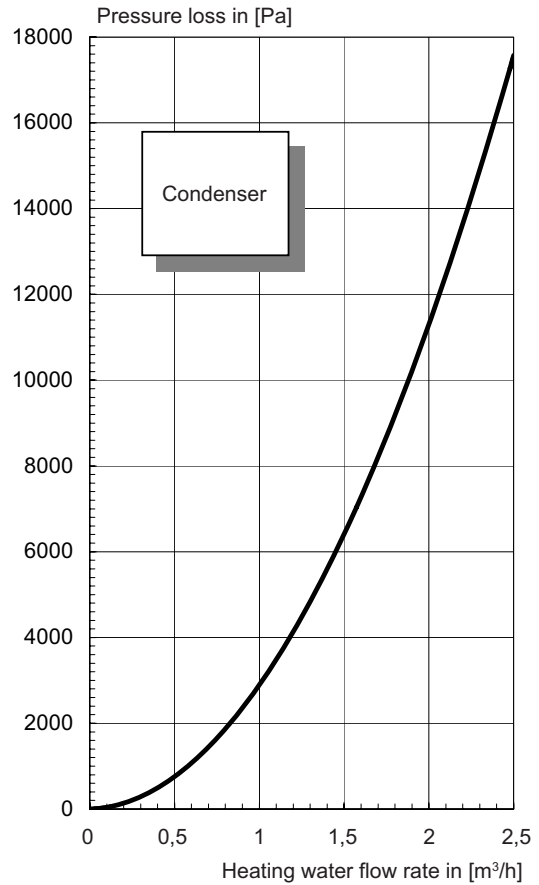
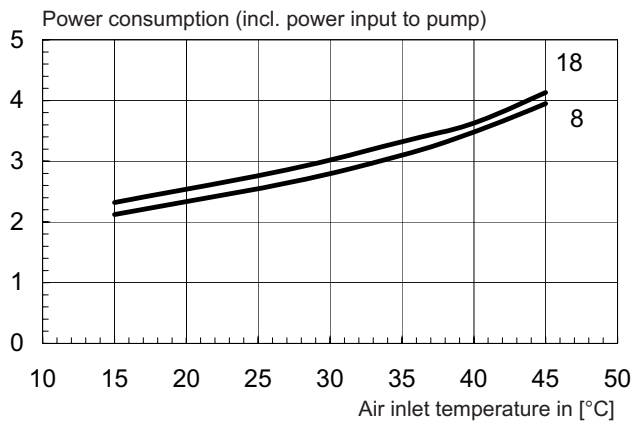
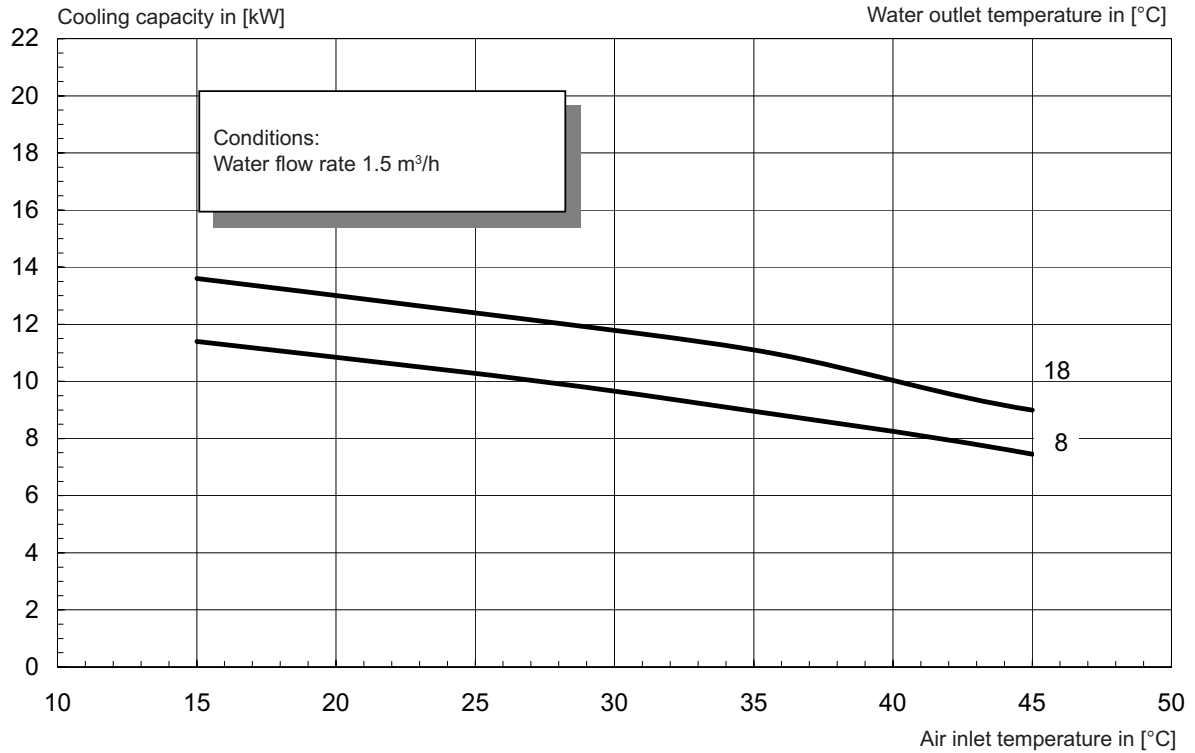

12.3.7 Heating mode LA 12TR

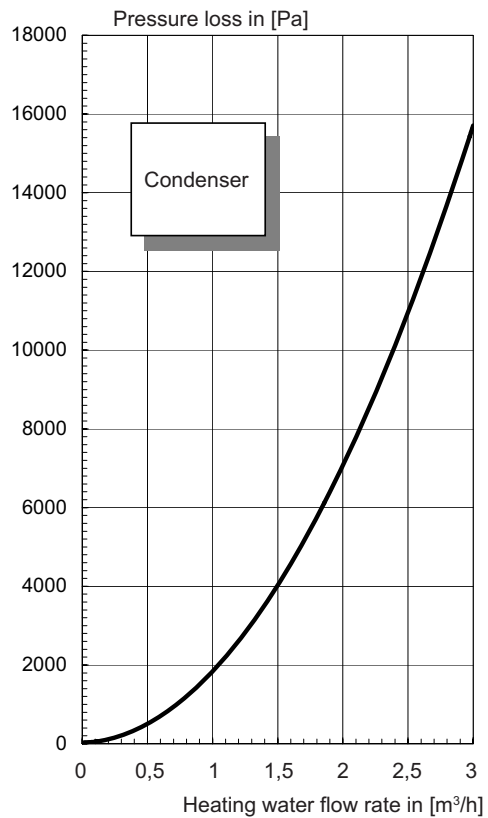
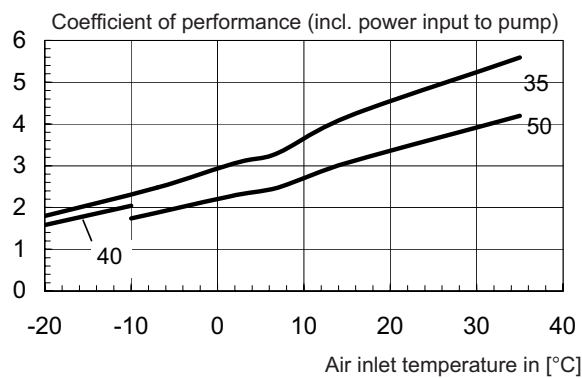
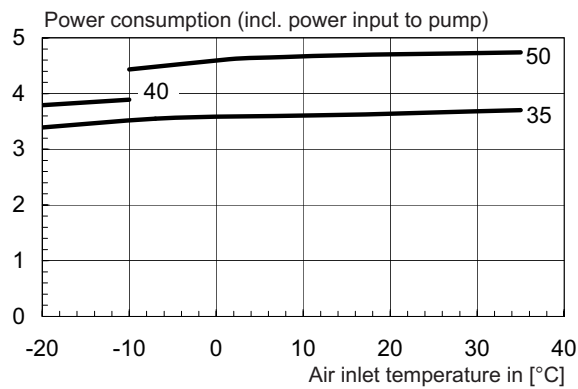
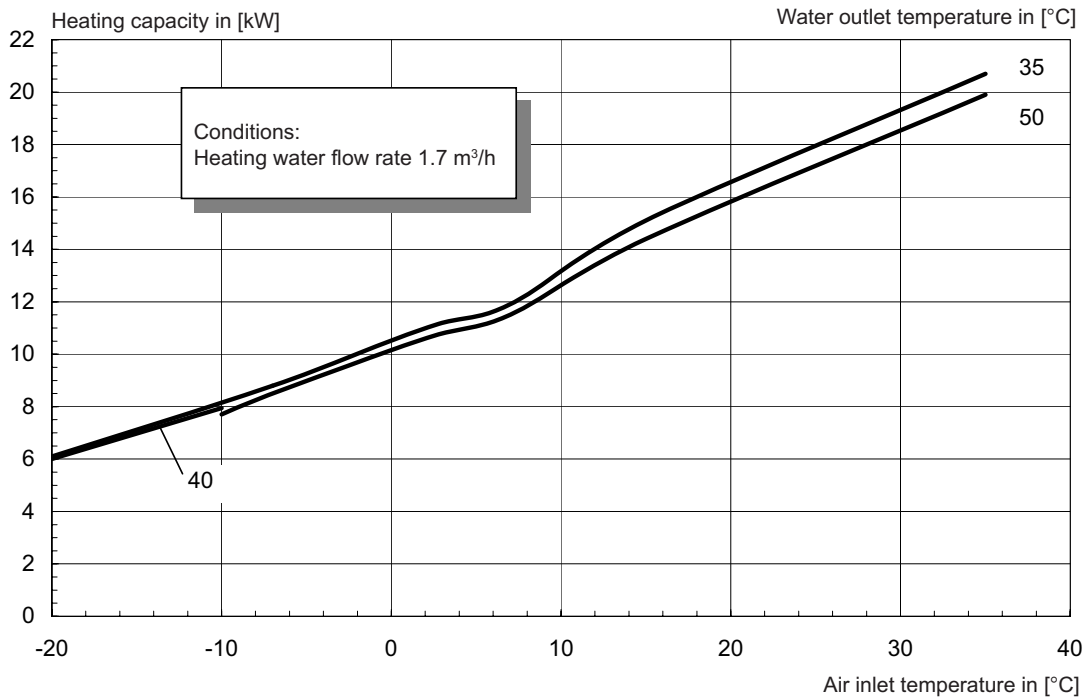

12.3.8 Cooling mode LA 12TR

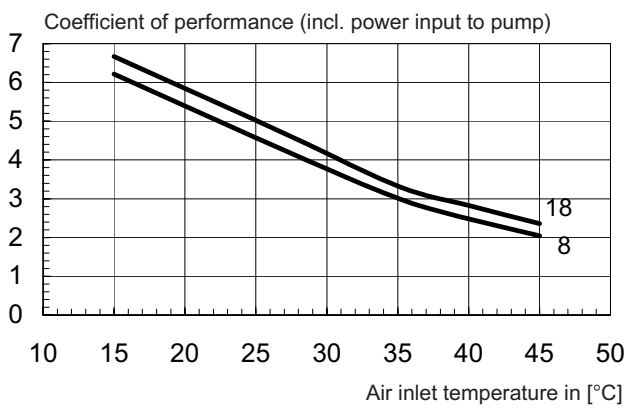
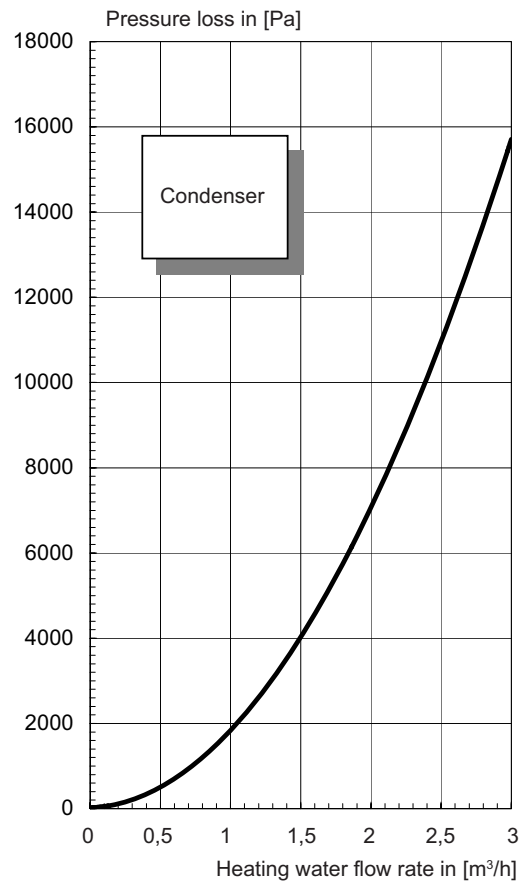
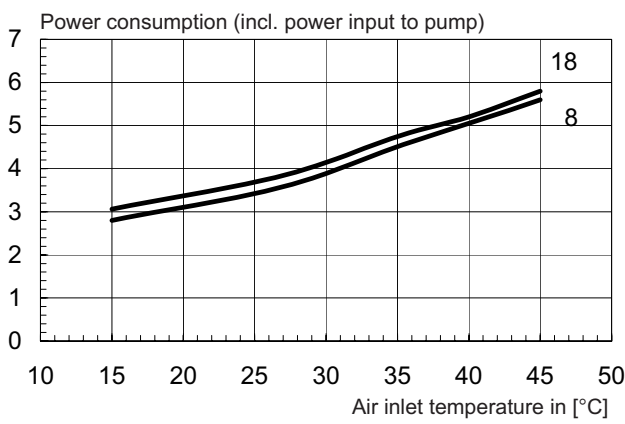
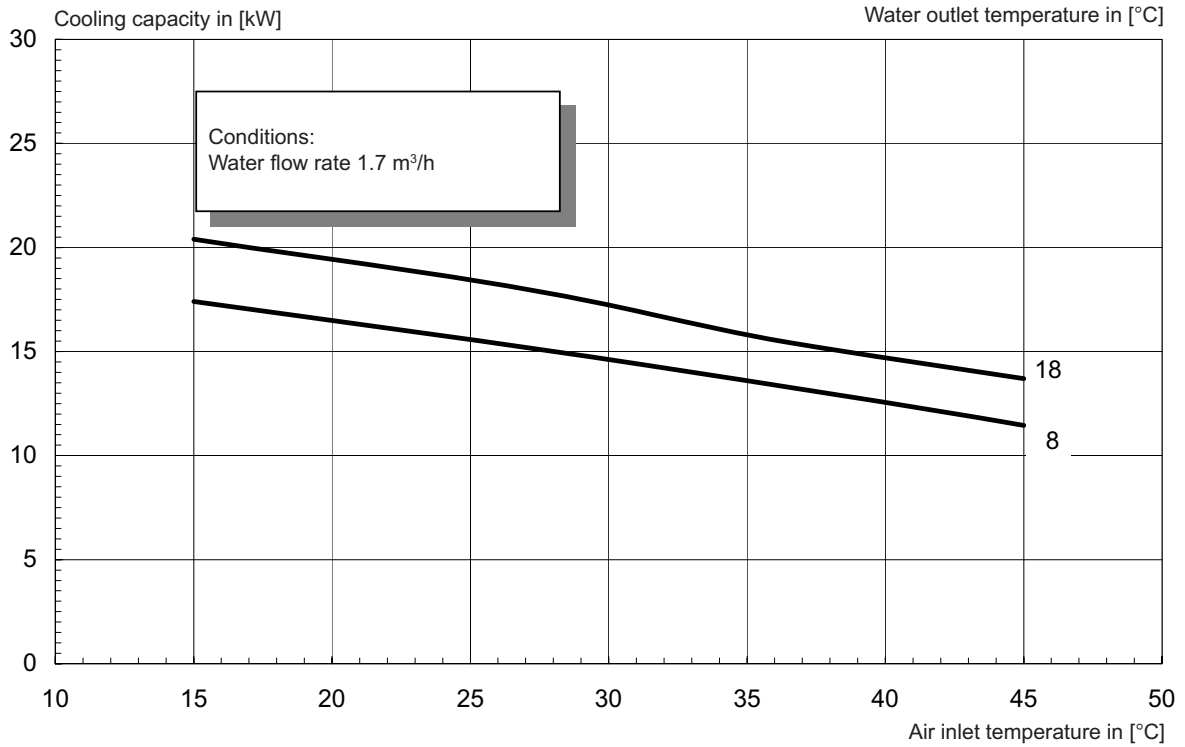

12.3.9 Heating mode LA 16TR

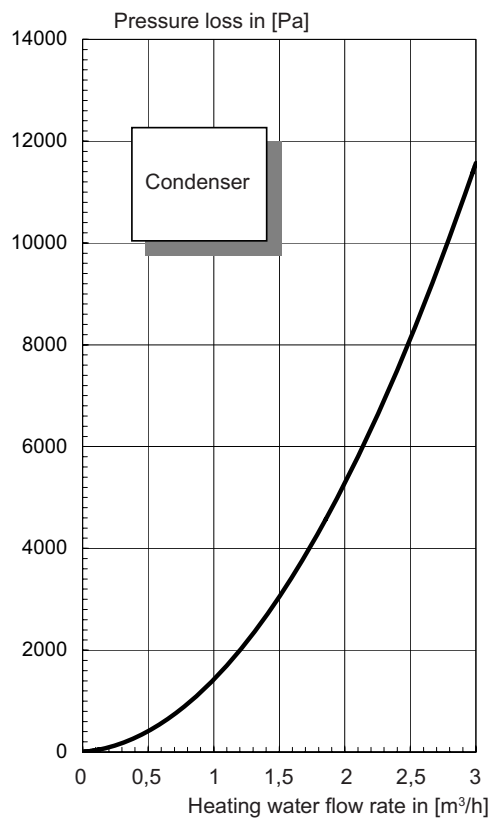
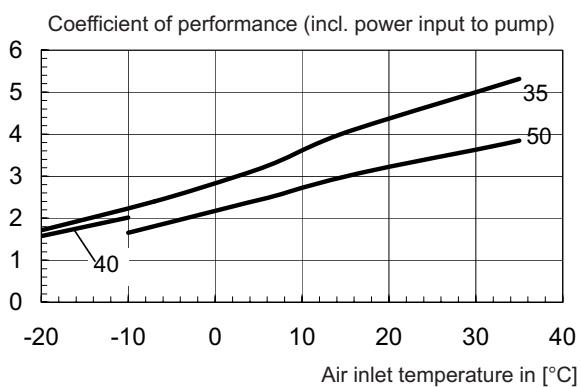
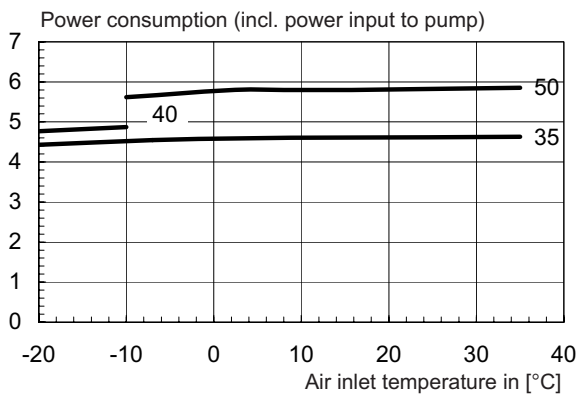
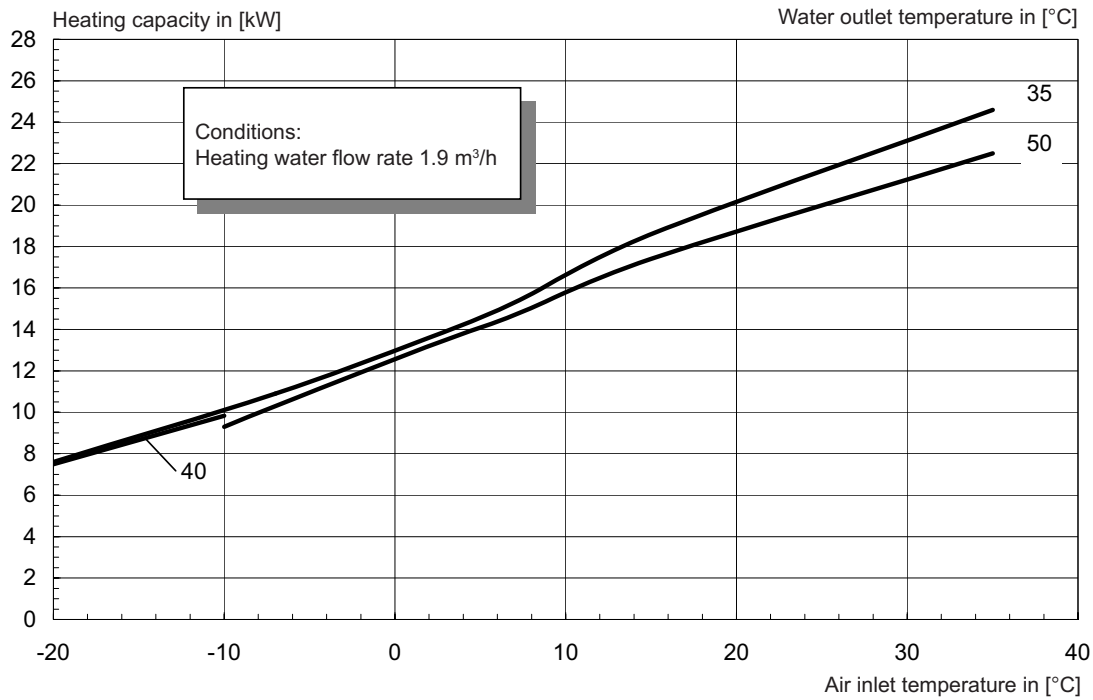

12.3.10 Cooling mode LA 16TR

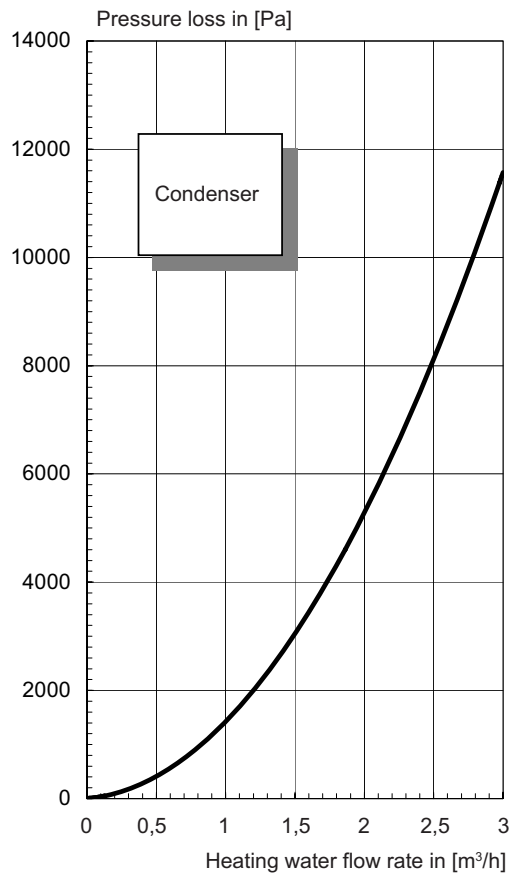
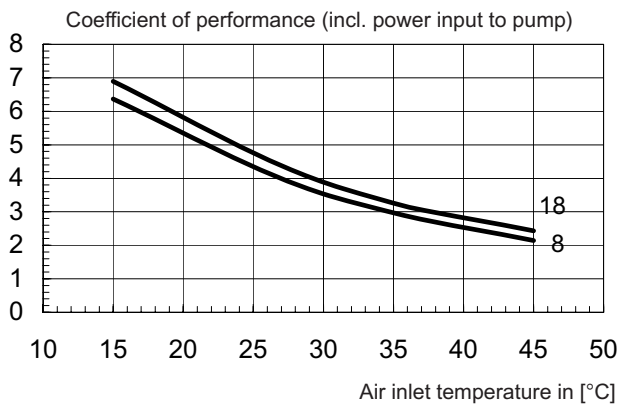
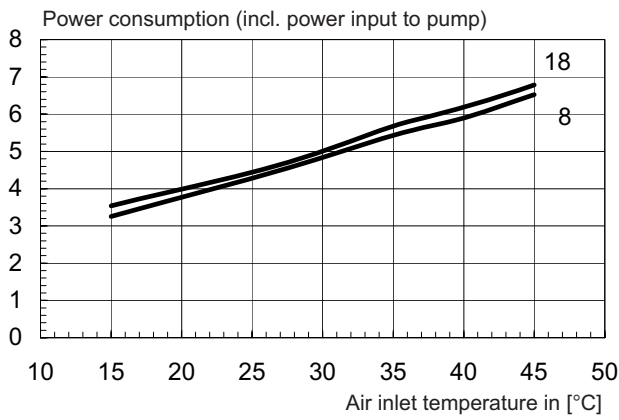
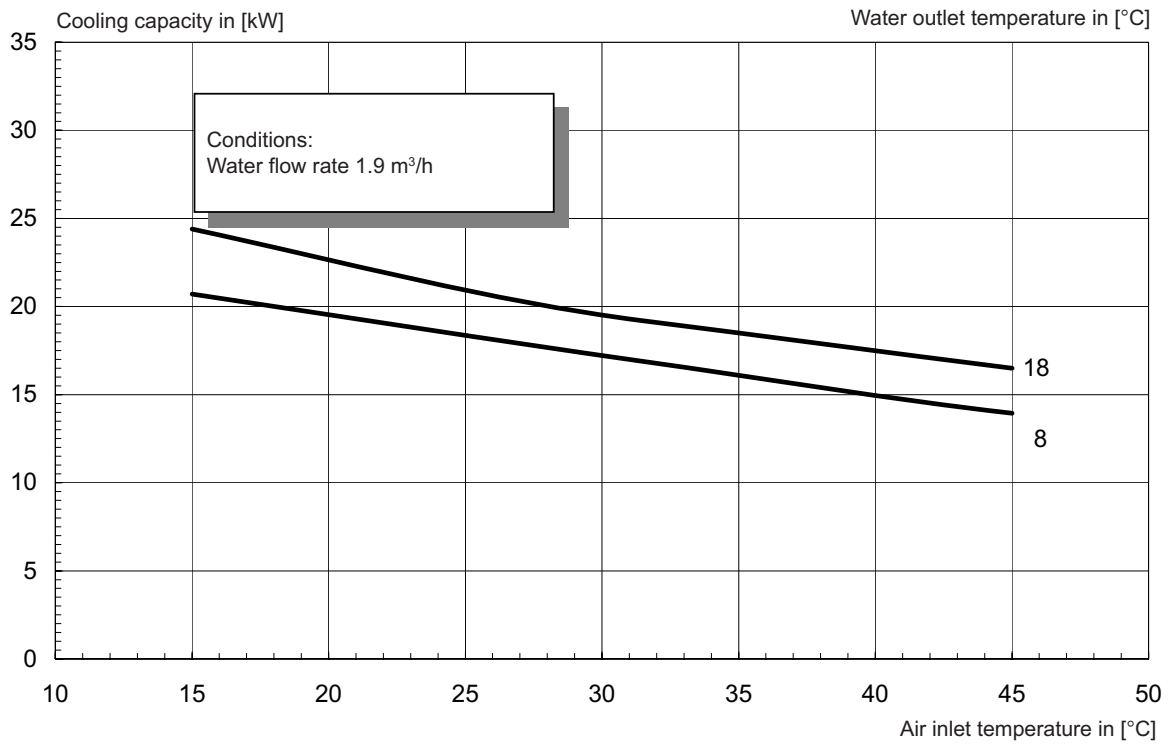

# APPENDIX: 12.4 WIRING DIAGRAMS

## 12.4.1 Control LA 6MR-LA 10MR

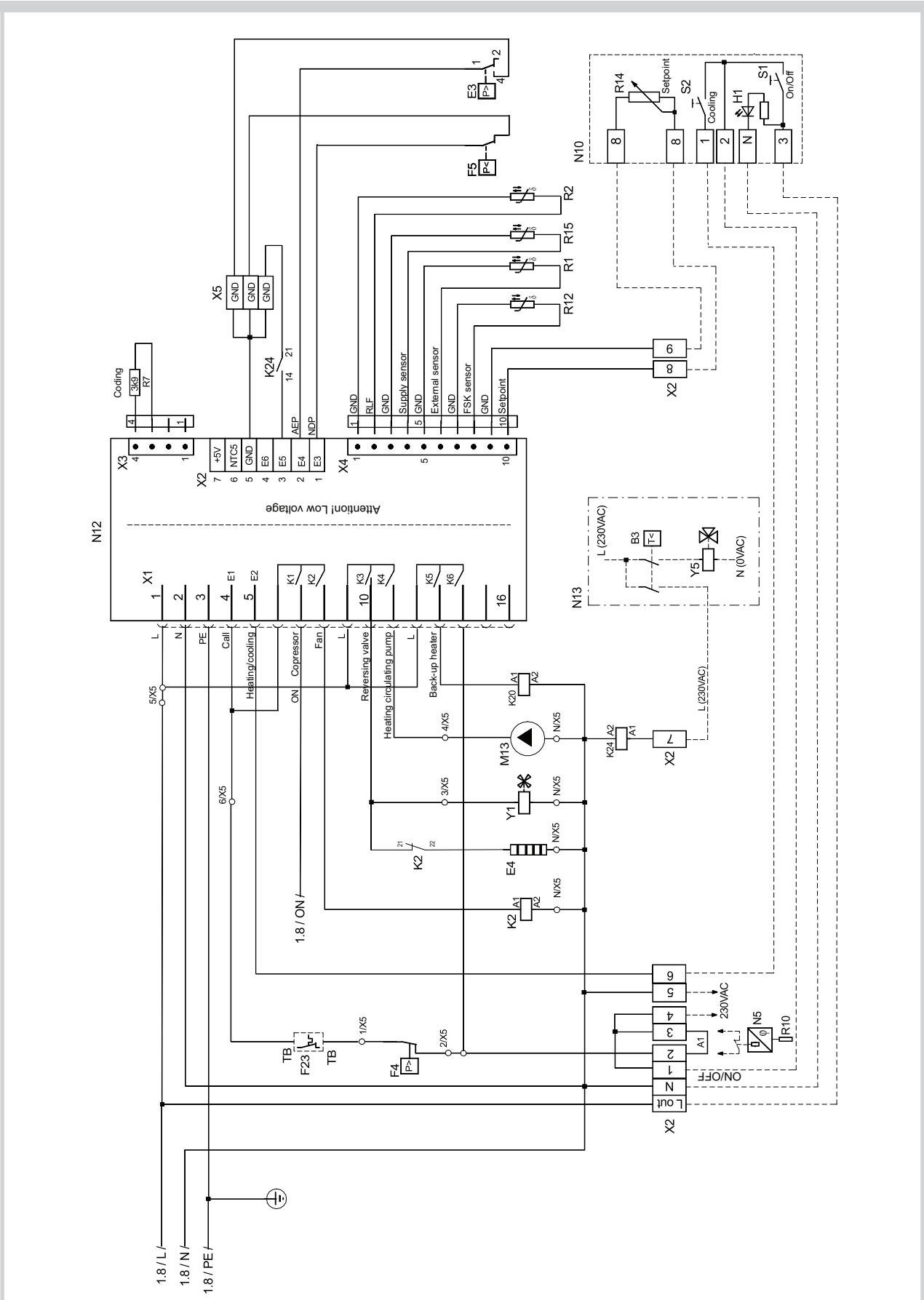



12.4.2 Load LA 6MR-LA 10MR

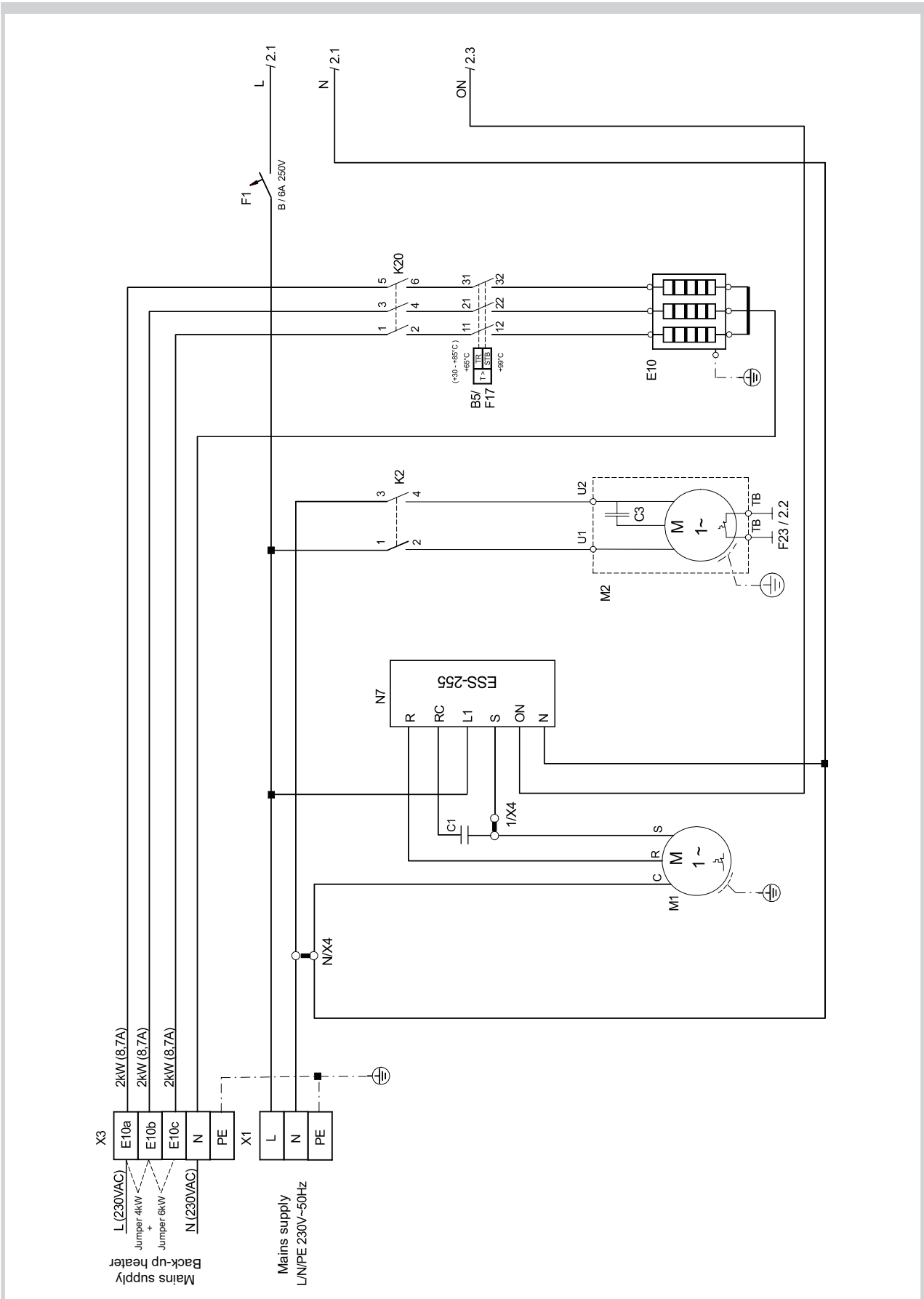

12.4.3 Terminal Diagram LA 6MR-LA 10MR

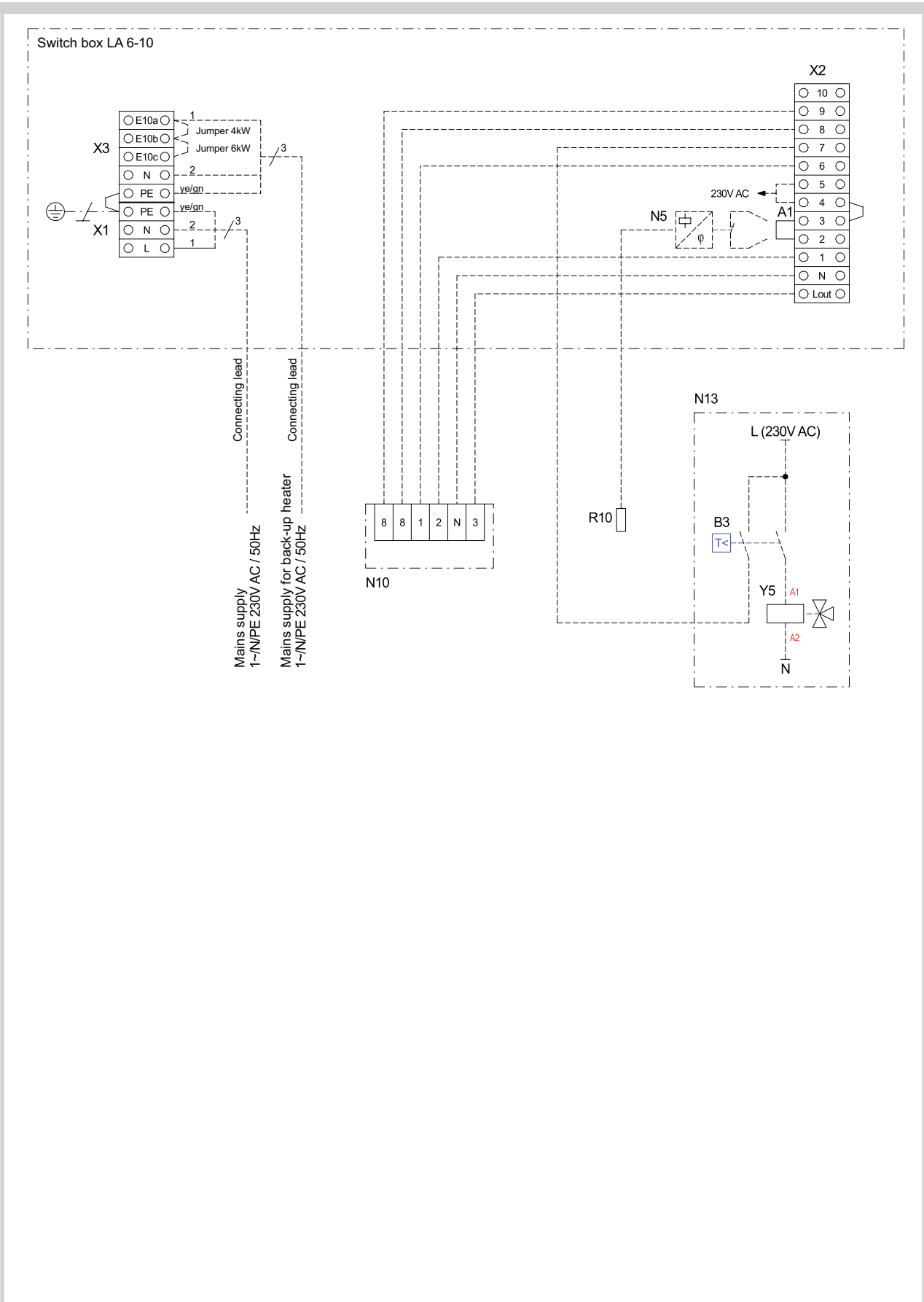

**12.4.4 Legend LA 06MR-LA10MR**

A1	Wire jumper: The jumper must be removed for external control (via potential-free contact) or when a dew point monitor (via potential-free contact) is used.
B3*	Thermostat, hot water
B5	Control thermostat, back-up heater
C1	Operating capacitor, compressor
C3	Operating capacitor, fan
E3	Pressostat, defrost end
E4	Nozzle ring heater
E10	Back-up heater
F1	Control fuse
F4	Pressostat, high pressure
F5	Pressostat, low pressure
F17	Safety temperature limiter, back-up heater
H1**	LED, ready for operation
K2	Contactator, fan
K20	Contactator, back-up heater
K24	Relay, call for hot water
M1	Compressor
M2	Fan
M13	Heating circulating pump
N5*	Dew point monitor
N7	Soft starter
N10	Remote control
N12	Control board
N13*	Switch group, hot water
R1	External sensor
R2	Return sensor
R7	Coding resistor
R10*	Moisture sensor
R12	Frost protection sensor, cooling mode (water)
R14**	Setpoint potentiometer
R15	Flow sensor
S1**	Control switch HP ON/OFF
S2**	Change-over switch HEATING/COOLING
X1	Terminal strip, mains L/N/PE - 230 V AC / 50 Hz
X2	Terminal strip, external components
X3	Terminal strip, back-up heater
X4	Terminal strip, compressor
X5	Terminal strip, internal wiring
Y1	4-way reversing valve heating/cooling
Y5*	3-way reversing valve for domestic hot water preparation
*	Parts to be provided by the client
**	Parts are integrated into the remote control

12.4.5 Control LA 12TR-LA 16TR

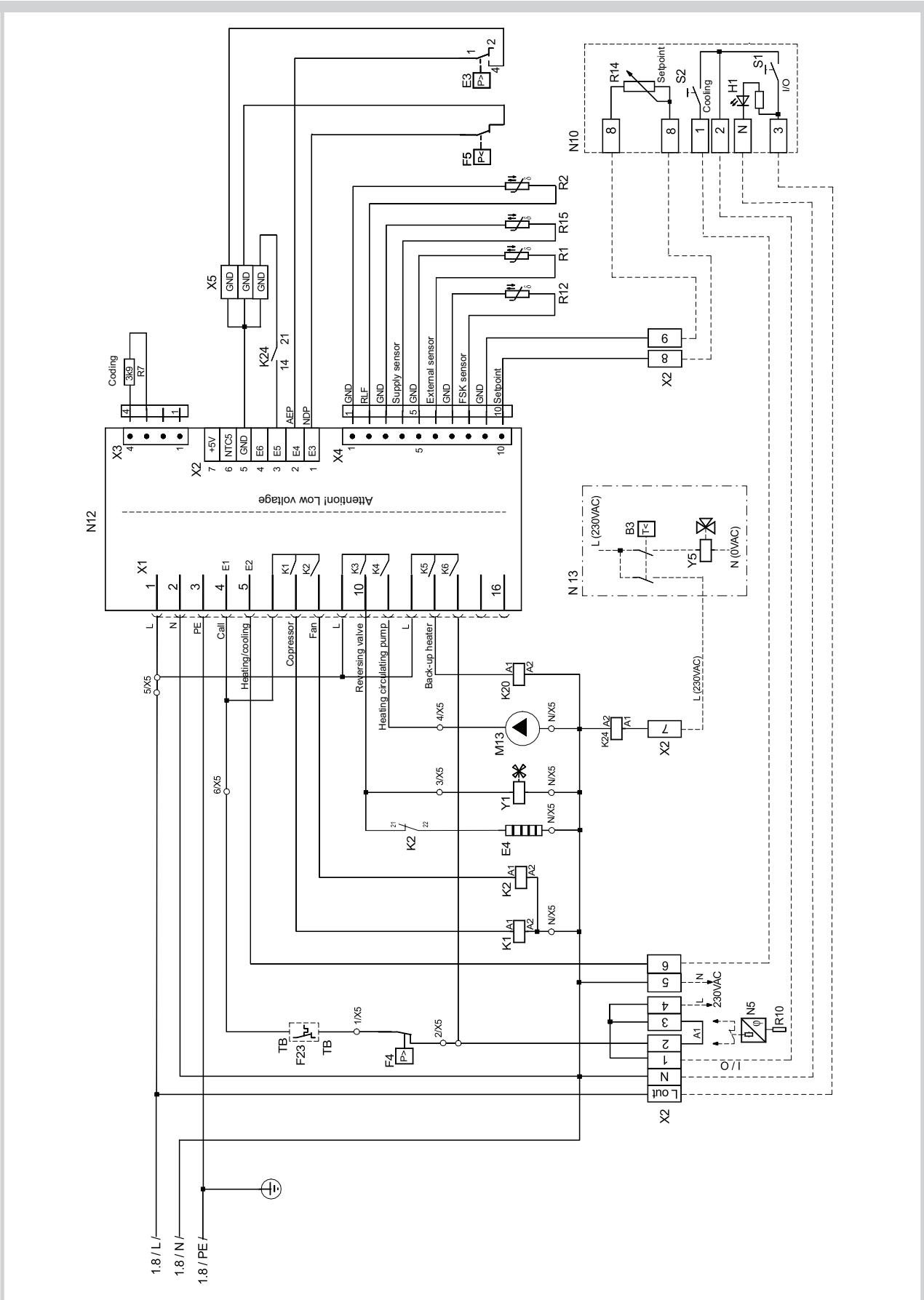

12.4.6 Load LA 12TR-LA 16TR

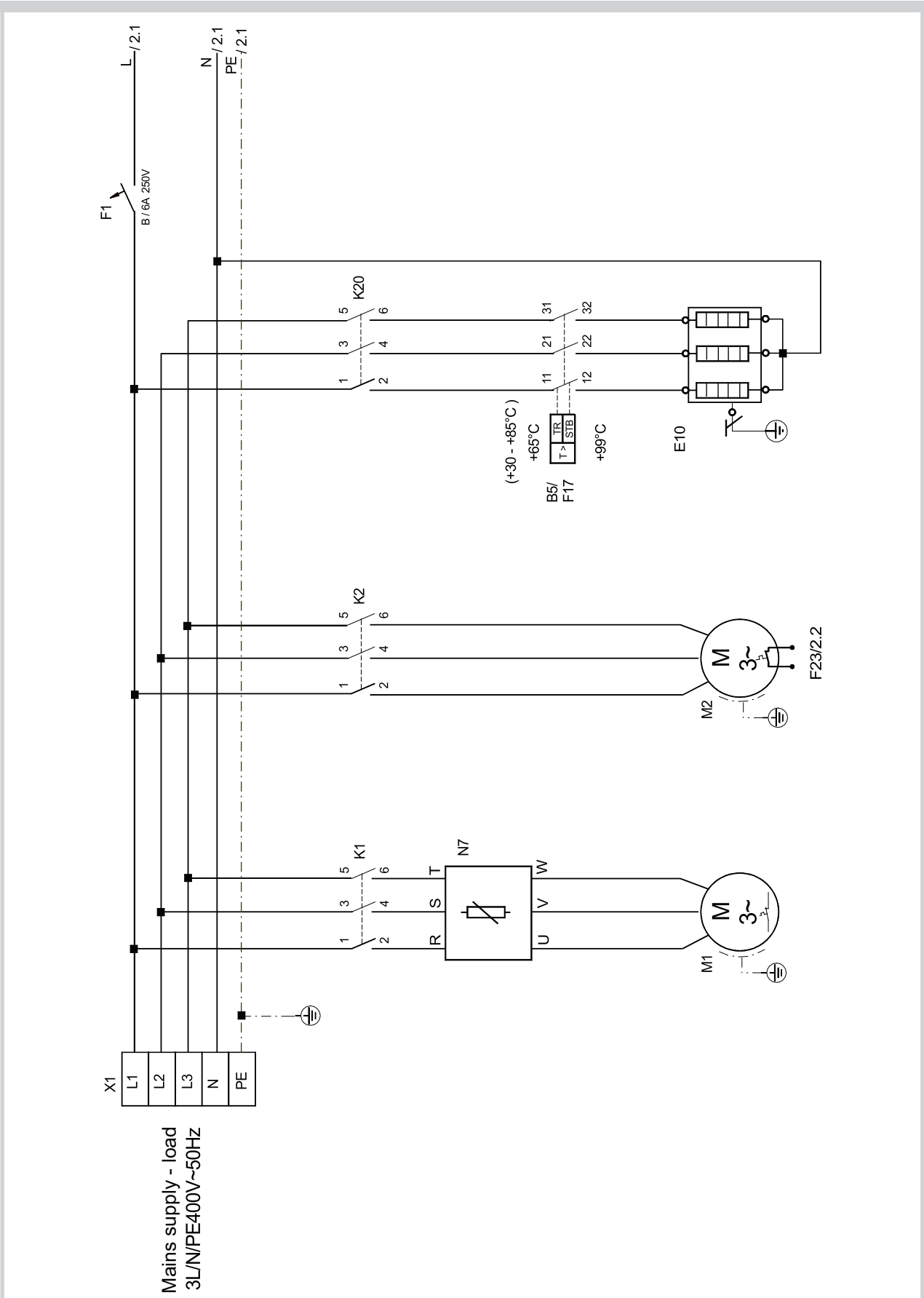

12.4.7 Terminal Diagram LA 12TR-LA 16TR

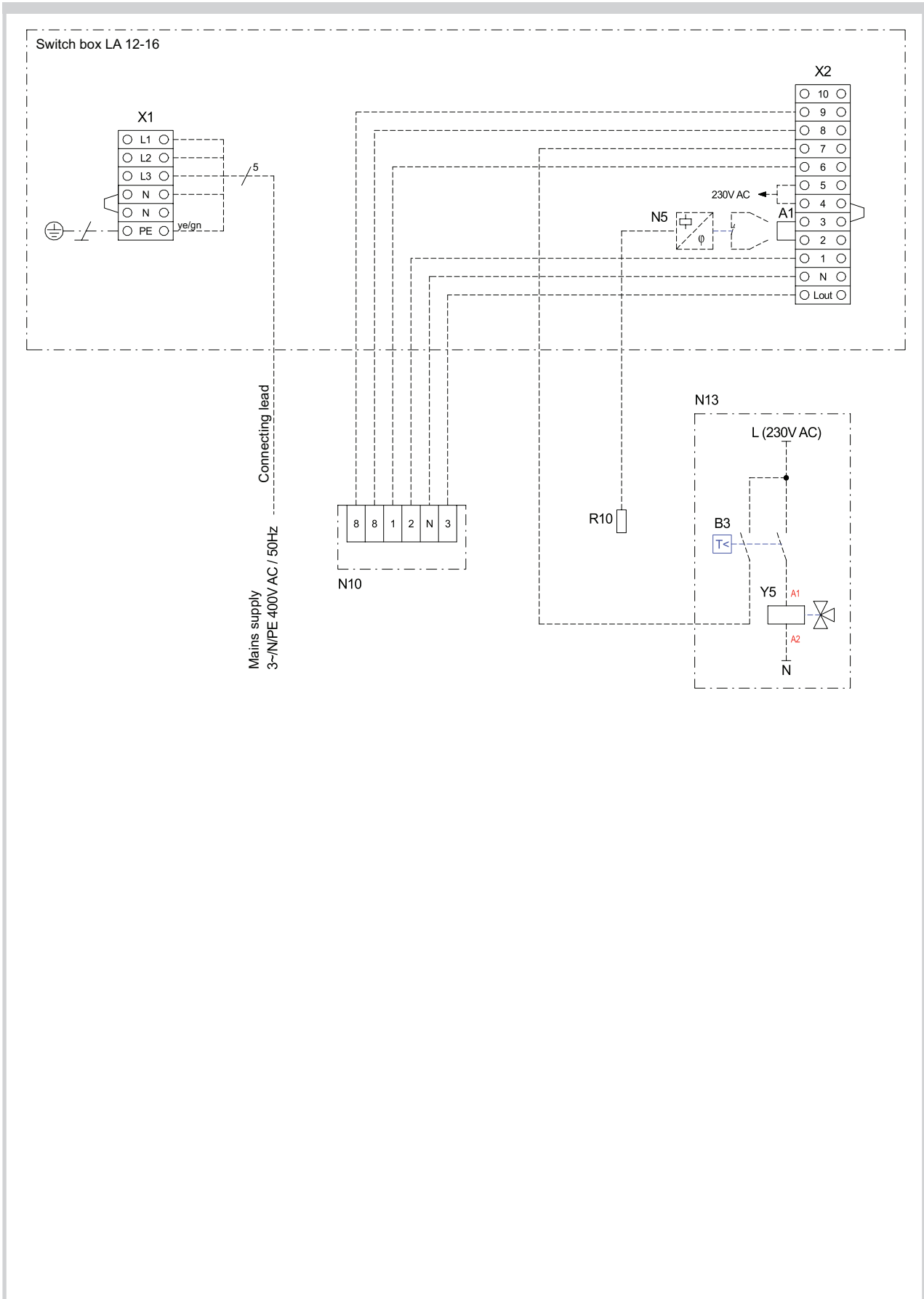

12.4.8 Legend LA 12TR-LA 16TR

A1	Wire jumper: For external control (via potential-free contact) or use of a dew point monitor (via potential-free contact) the jumper must be removed.
B3*	Hot water thermostat
B5	Control thermostat, back-up heater
E3	Pressostat defrost end
E4	Nozzle ring heater
E10	Back-up heater
F1	Control-circuit fuse
F4	Pressostat, high pressure
F5	Pressostat, low pressure
F17	Safety temperatur limiter, back-up heater
F23	Bimetal contact, fan
H1**	LED, ready for operation
K1	Contactora, compressor
K2	Contactora, fan
K20	Contactora, back-up heater
K24	Relay, call for domestic hot water
M1	Compressor
M2	Fan
M13	Heating circulating pump
N5*	Dew point monitor
N7	Soft starter
N10	Remote control
N12	Control board
N13*	Schaltgruppe, hot water
R1	External sensor
R2	Return sensor
R7	Coding resistor
R10*	Moisture sensor
R12	Frost protection sensor, cooling mode (water)
R14**	Setpoint potentiometer
R15	Flow sensor
S1**	Control switch HP ON/OFF
S2**	Change-over switch HEATING/COOLING
X1	Terminal strip, mains L/N/PE - 230 V AC / 50 Hz
X2	Terminal strip, external components
X5	Terminal strip, internal wiring
Y1	4-way reversing valve heating/cooling
Y5*	3-way reversing valve for domestic hot water preparation

\* Parts to be provided by the client

\*\* Parts are integrated into the remote control

12.5.1 Mono-energetic system

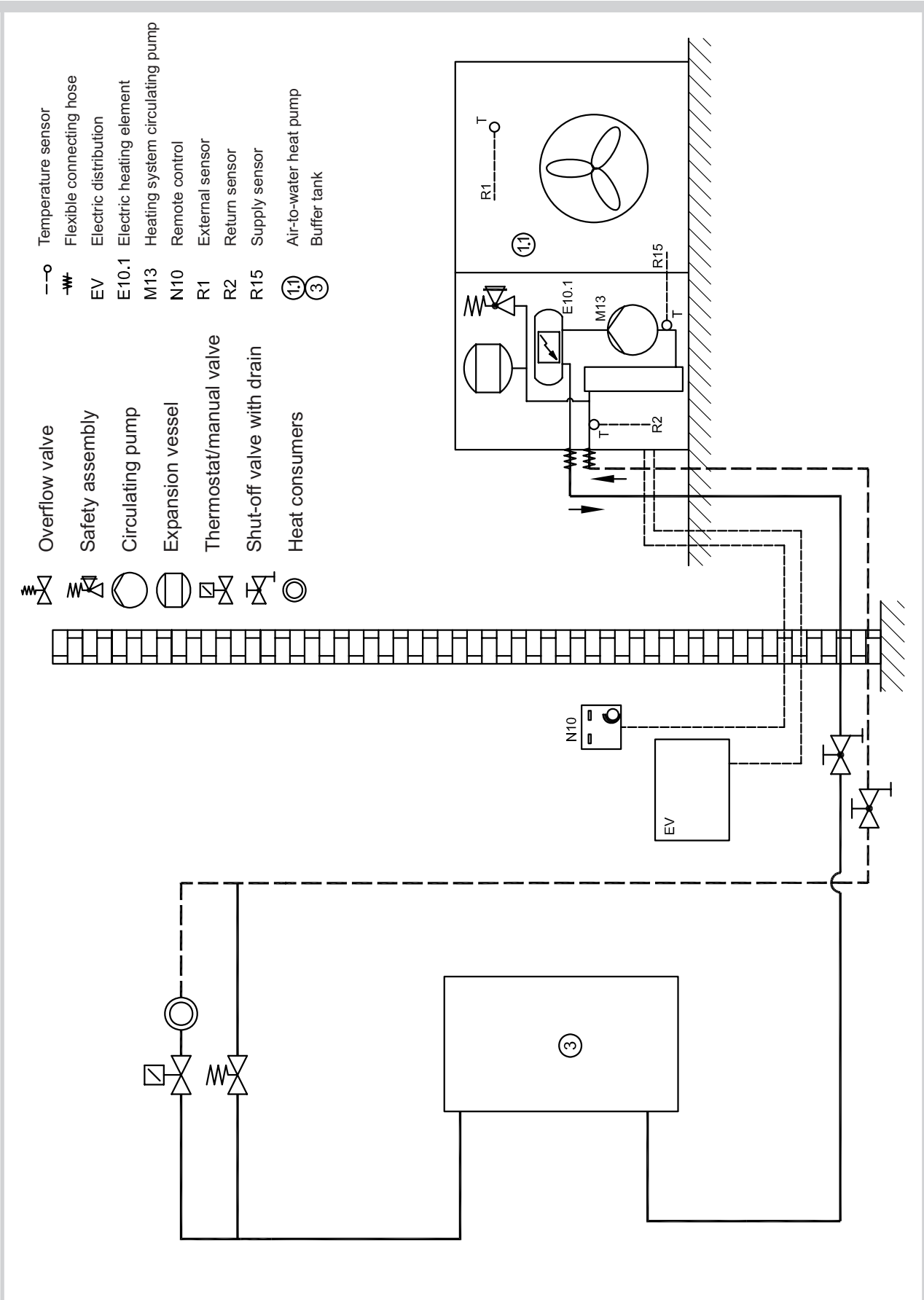



12.5.2 Mono-energetic systems and domestic hot water function

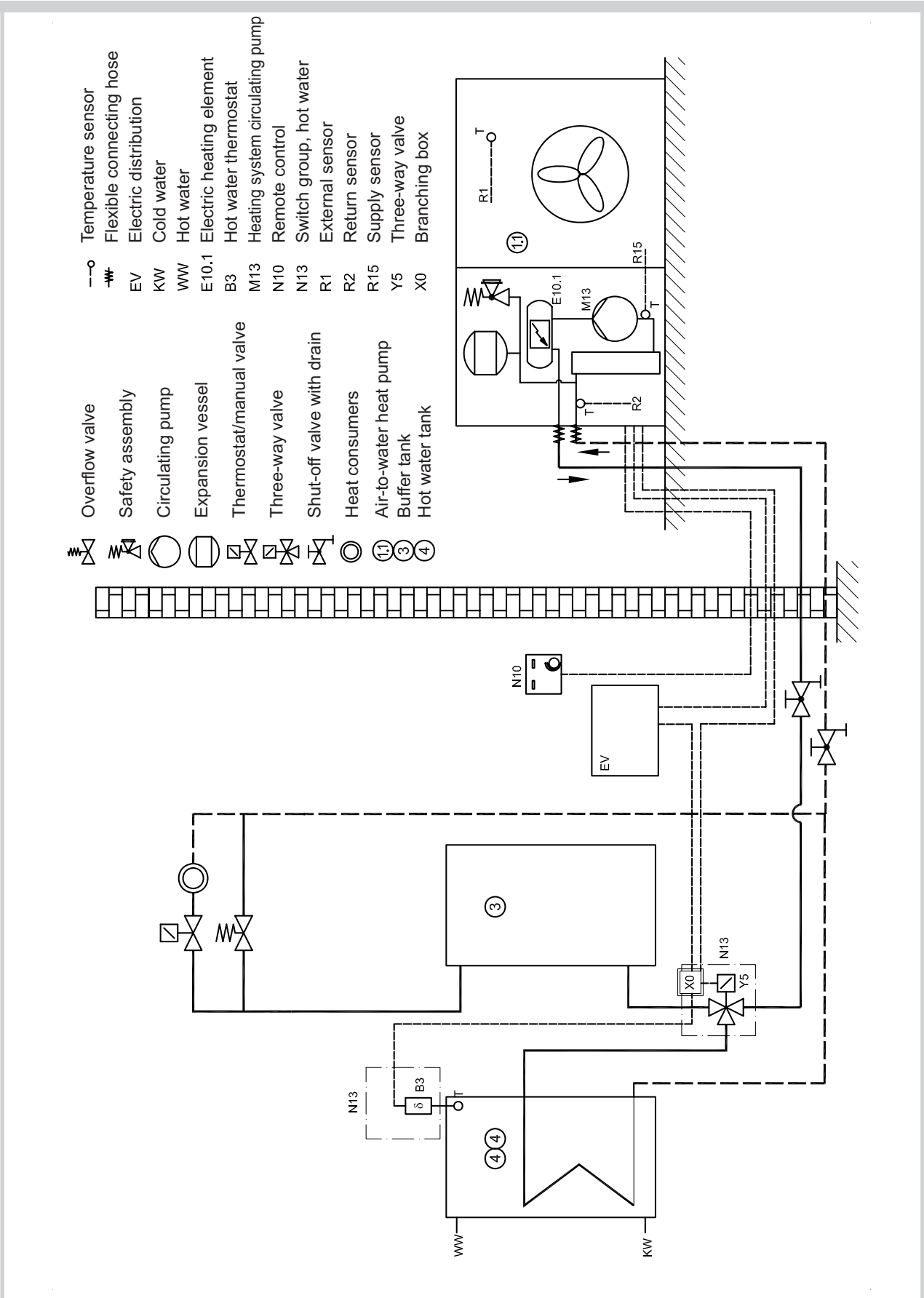

EC Declaration of Conformity



Declaration of Conformity



The undersigned

Glen Dimplex Deutschland GmbH  
 Division Dimplex  
 Am Goldenen Feld 18  
 D-95326 Kulmbach

hereby confirm that the design and construction of the product(s) listed below, in the version(s) placed on the market by us, conform to the relevant requirements of the applicable EC directives.

This declaration becomes invalidated if any modifications are made to the product(s) without our prior authorization.

Designation of the product(s):

**Air-to-water heat pumps**  
 for outdoor installation  
 containing R407C

EC Directives:

EC Directive for Low Voltage  
 (73/23/EEC)  
 EC Directive for Electromagnetic Compatibility (EMC)  
 (89/336/EEC)  
 Pressure Equipment Directive  
 (97/23/EEC)

Type(s):

LA 6MR  
 LA 8MR  
 LA 10MR  
 LA 12TR  
 LA 16TR

Harmonized EN Standards:

EN 255:1997  
 EN 378:1994  
 DIN EN 60335-1 (VDE 0700 Teil1):1995-10  
 DIN EN 60335-1/A1 (VDE 0700 Teil1/A1):1997-08  
 DIN EN 60335-1/A12 (VDE 0700 Teil 1/A12):1997-08  
 DIN EN 60335-1/A13 (VDE 0700 Teil 1/A13):1998-12  
 DIN EN 60335-1/A14 (VDE 0700 Teil 1/A14):1999-05  
 DIN EN 60335-2-40 (VDE 0700 Teil 40):1998-07  
 DIN EN 55014-2 (VDE 0875 Teil 14-2):1997-10  
 Requirements of category II  
 DIN EN 55014-1 (VDE 0875 Teil 14-1):1999-10  
 DIN EN 61000-3-2 (VDE 0838 Teil 2):1998-10  
 DIN EN 61000-3-2/A14 (VDE 0838 Teil 2/A14):2001-01  
 DIN EN 61000-3-3 (VDE 0838 Teil 3):1996-03  
 EN 60335-1:1994+A11:1995  
 EN 60335-1/A1:1996  
 EN 60335-1/A12:1996  
 EN 60335-1/A13:1998  
 EN 60335-1/A14:1998  
 EN 60335-2-40:1997  
 EN 55014-2:1997  
 EN 55014-1:1993+A1:1997+A2:1999  
 EN 61000-3-2:1995+  
 Corrigendum:1997+A1:1998+A2:1998  
 EN 61000-3-2:1995/A14:2000  
 EN 61000-3-3:1995

Order No.:

350 790  
 350 800  
 350 810  
 350 820  
 350 830

National Standard/Directives:

<u>D</u>	<u>A</u>	<u>CH</u>
VBG20		SVTI

Wolfgang Weinhold  
 General Manager

Mathias Huprich  
 Technical Director

Kulmbach, 01.06.2005



